

UPDATE : 10/8/2015

**MỨC LƯỚI
INDEX**

Thuyết minh cách số định danh mức phụ tùng

HOW TO USE THIS PART CATALOGUE

Các bộ phận động cơ

CONTENTS - ENGINE GROUP

.....1

Các bộ phận khung sườn

CONTENTS - FRAME GROUP

.....4

Danh mục các phụ tùng trong động cơ

ENGINE PARTS CATALOGUE

.....7

Danh mục các phụ tùng trong khung sườn

FRAME PARTS CATALOGUE

.....33

Bảng tra mã số phụ tùng

PARTS INDEX

.....65

THUYẾT MINH CÁCH SỐ ĐỊNH DANH MỨC PHỤ TÙNG

PHÂN LOẠI MÃ SỐ PHỤ TÙNG

1. Bộ phận động cơ
2. Bộ phận khung sườn

Qui cách mã số chi tiết

Ví dụ: Một nhóm bộ phận

00000 - 000 - 0000 - 00

Mã số boả Chuông Soá qui ðòuc xuaát
boả loai mãy Maó soá caúi bieán thieát

Ví dụ: Bulon, ñai óac vaø caùc phuï tuøng tieâu chuaån khaùc

00000 - 00000 - 00

Mã số boả phaán Kích boả phaán thòòuc Mã số maøu saéc

CAÙC TÒØ VIEÁT TAÉT

Ass'y	Assembly	MPH	Miles per hour
Comp.	Complete	L (100L)	Link (100 Links)
R	Right	A.C	Alternating Current
L	Left	D.C	Direct Current
STD	Standard	IN	Inlet

mm	Millimeter	EX	Exhaust
T (22T)	Tooth (22 Teeth)	FR	Front
A	Ampere	RR	Rear
V	Volt	HEX	Hexagonal
W	Watt	A.M	Attaching mark

KPH	Kilometers per hour	T.M	Transcript mark
-----	---------------------	-----	-----------------

KÍCH THỔÙC

Phụ tùng	Ví dụ	Nhãn biếát
Bulon (Vít)	6x12	Ñòðøng kính 6 mm, chieàu daøi 12 mm
Choát ñònh v	8x14	Ñòðøng kính 8 mm, chieàu daøi 14 mm
Voøng O-ring	9.5x1.6	Ñòðøng kính 9.5 mm, beà daày 1.6 mm
Phoát daàu	14x24x5	Ñòðøng kính trong 14 mm, ñòðøng kính ngoaøi 24 mm, beà daày 5 mm
OÁng daãn	5x130	Ñòðøng kính trong 5 mm, chieàu daøi 130

HOW TO USE THIS PARTS CATALOGUE

MAKE UP OF THE PARTS NUMBER

1. Engine group
 2. Frame group
- Functional code of part number

Example: General parts

00000 - 000 - 0000 - 00

Function and component number Model code Manufacture code Modification designation

Example: Bolts, nuts, and other standard parts

00000 - 00000 - 00

Function and component number Dimension Chemisical surface treatment

ABBREVIATIONS

Ass'y	Assembly	MPH	Miles per hour
Comp.	Complete	L (100L)	Link (100 Links)
R	Right	A.C	Alternating Current
L	Left	D.C	Direct Current
STD	Standard	IN	Inlet

mm	Millimeter	EX	Exhaust
T (22T)	Tooth (22 Teeth)	FR	Front
A	Ampere	RR	Rear
V	Volt	HEX	Hexagonal
W	Watt	A.M	Attaching mark

KPH	Kilometers per hour	T.M	Transcript mark
-----	---------------------	-----	-----------------

DIMENSION

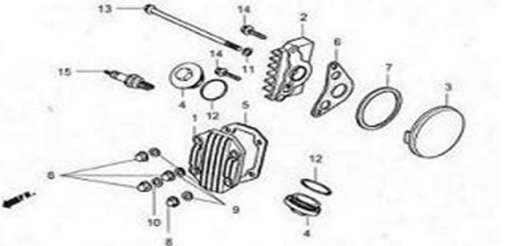
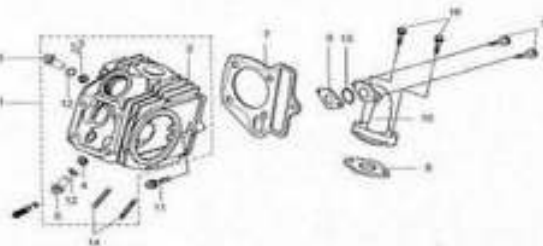
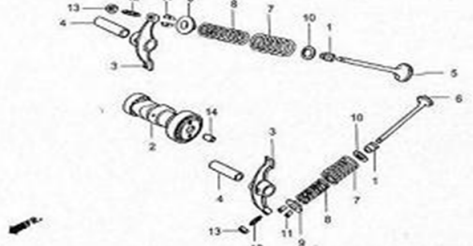
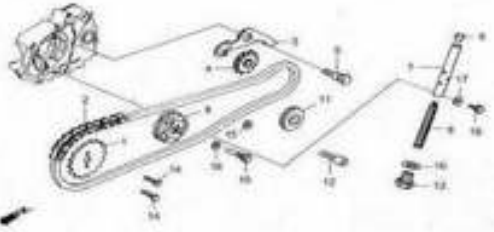
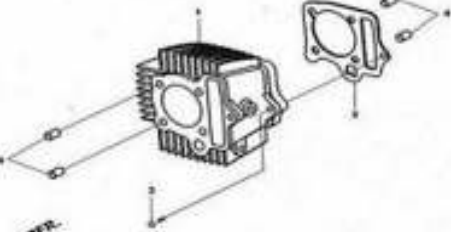
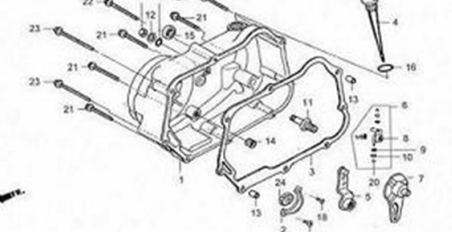
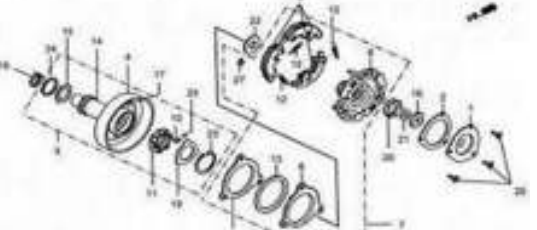
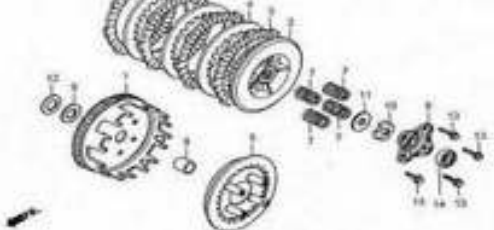
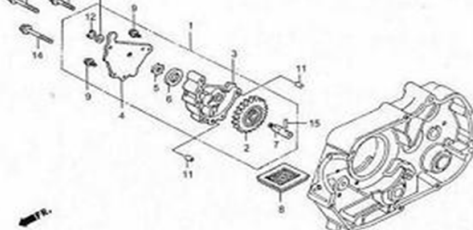

Parts	Example	Interpretation
Bolt (screw)	6x12	6 mm diameter, 12 mm length
Pin	8x14	8 mm diameter, 14 mm length
O-ring	9.5x1.6	9.5 mm diameter, 1.6 mm thickness
Oil seal	14x24x5	14 mm inside diameter, 24 mm outside diameter, 5 mm thickness
Tube	5x130	5 mm inside diameter, 130 mm length

CÁC BỘ PHẬN CỦA ĐỘNG CƠ
CONTENTS - ENGINE GROUP

<p>E-01 Cylinder head cover</p>	<p>E-02 Cylinder head ass'y</p>	<p>E-03 Cam shaft, valve</p>
		
<p>E-04 Cam chain, tensioner</p>	<p>E-05 Cylinder</p>	<p>E-06 Right crank case cover</p>
		
<p>E-07 Centrifugal clutch ass'y</p>	<p>E-08 Clutch outer ass'y</p>	<p>E-09 Oil pump ass'y</p>
		

PRICE SHOWN IS PER PIECE. PRODUCT IMAGE PRICES ARE APPROXIMATE GUIDE ONLY.
PRICES SHOWN ARE SUBJECT TO CHANGE WITHOUT PRIOR NOTICE.

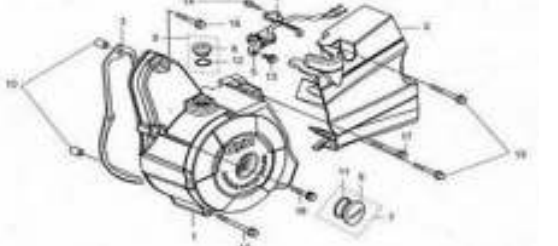
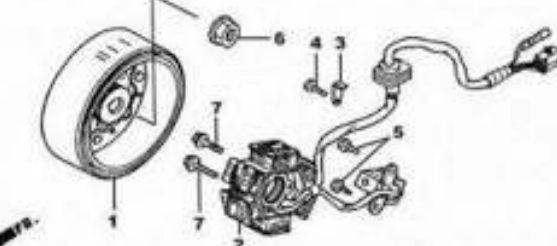
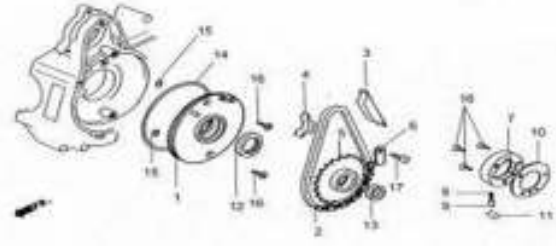
CÁC BỘ PHẬN CỦA ĐỘNG CƠ
CONTENTS - ENGINE GROUP

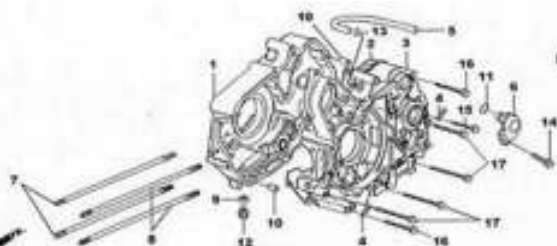
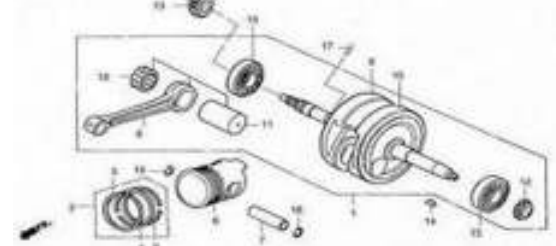
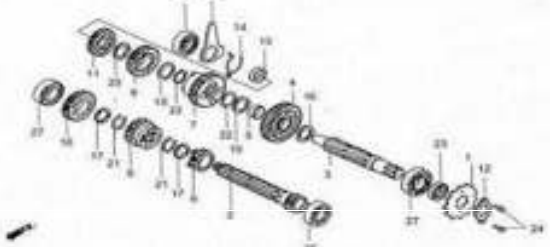
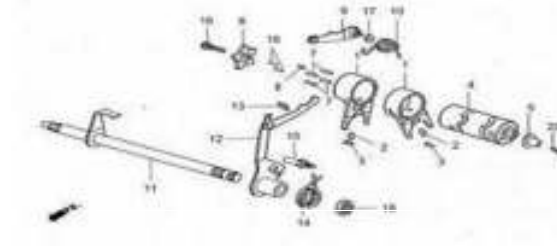
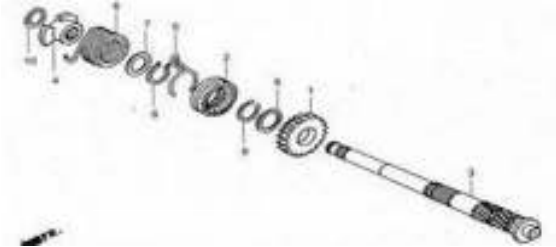
<p>E-10 Left crank case cover</p>	<p>E-11 Generator</p>	<p>E-12 Starting clutch</p>
		
<p>E-13 Starting motor</p>	<p>E-14 Crank case</p>	<p>E-15 Crank shaft comp. / Piston</p>
		
<p>E-16 Transmission</p>	<p>E-17 Gear shift drum</p>	<p>E-18 Kick starter spindle</p>
		

PRICE SHOWN IS PER PIECE. PRODUCT IMAGE PRICES ARE APPROXIMATE GUIDE ONLY.
PRICES SHOWN ARE SUBJECT TO CHANGE WITHOUT PRIOR NOTICE.

CÁC BỘ PHẬN CỦA ĐỘNG CƠ
CONTENTS - ENGINE GROUP

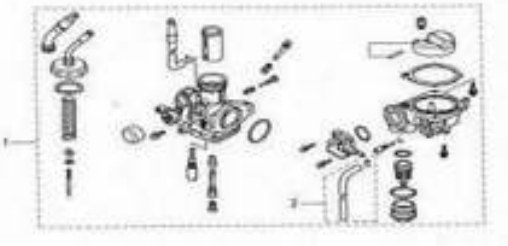
<p>E-19</p> <p align="center">Carburetor</p>		
		



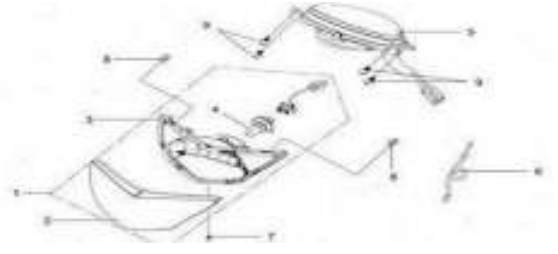
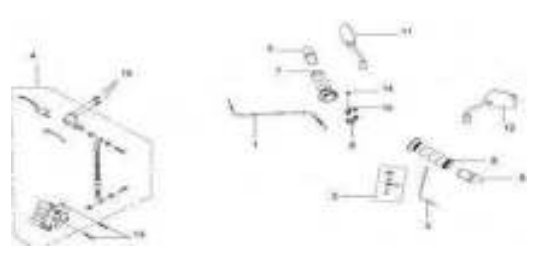
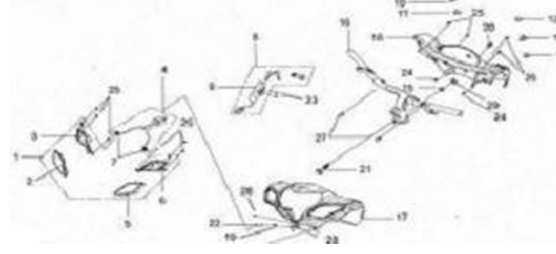
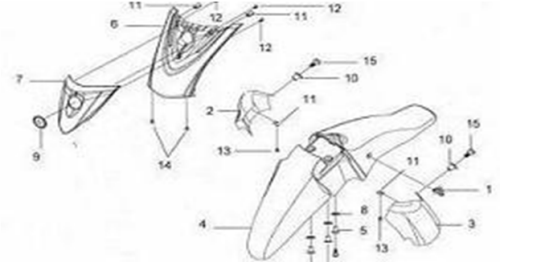
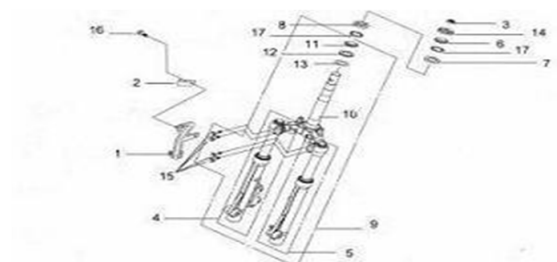
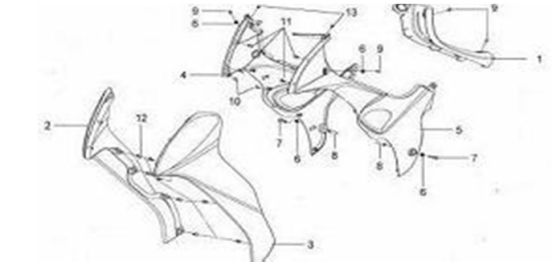
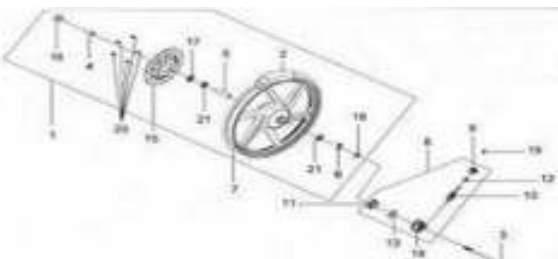
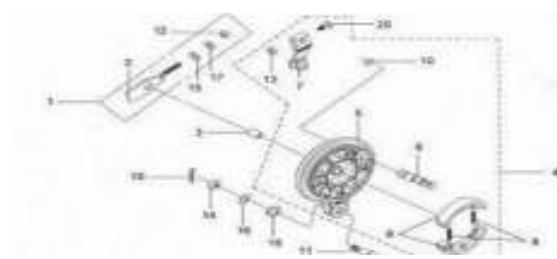
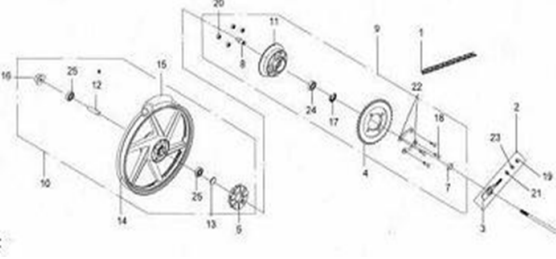

PRICE SHOWN IS PER PIECE. PRODUCT IMAGE PRICES ARE APPROXIMATE GUIDE ONLY.
PRICES SHOWN ARE SUBJECT TO CHANGE WITHOUT PRIOR NOTICE.

CÁC BỘ PHẬN CỦA KHUNG SUỒN
CONTENTS - FRAME GROUP

<p>F-01 Head light</p>	<p>F-02 Front brake - Back mirror</p>	<p>F-03 Handle cover</p>
		
<p>F-04 Top cover - Front fender</p>	<p>F-05 Front fork set</p>	<p>F-06 Front cover-Main pipe cover</p>
		
<p>F-07 Front wheel-Brake disk</p>	<p>F-08 Rear brake panel</p>	<p>F-09 Rear wheel</p>
		

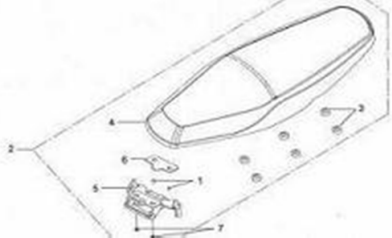
PRICE SHOWN IS PER PIECE. PRODUCT IMAGE PRICES ARE APPROXIMATE GUIDE ONLY.
 PRICES SHOWN ARE SUBJECT TO CHANGE WITHOUT PRIOR NOTICE.

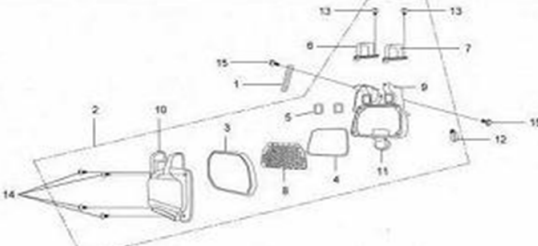
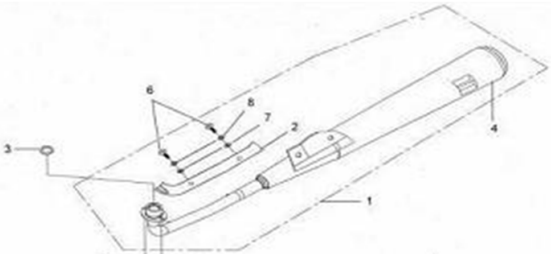
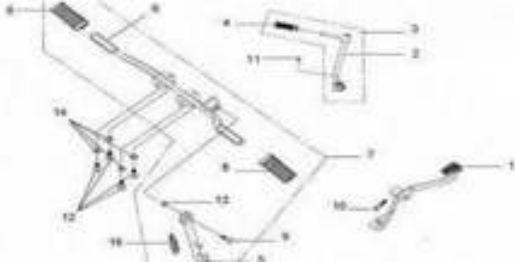
CÁC BỘ PHẬN CỦA KHUNG SUỒN
CONTENTS - FRAME GROUP

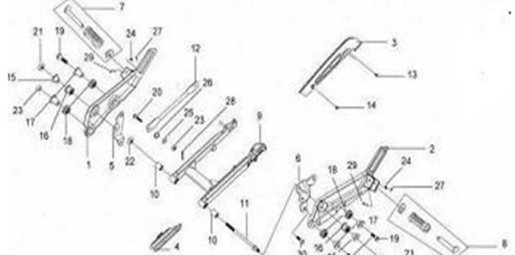
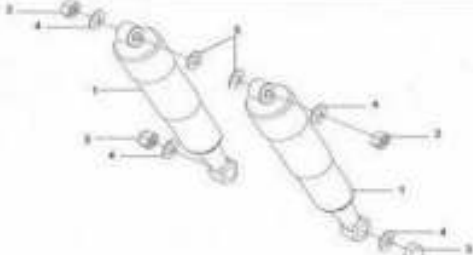
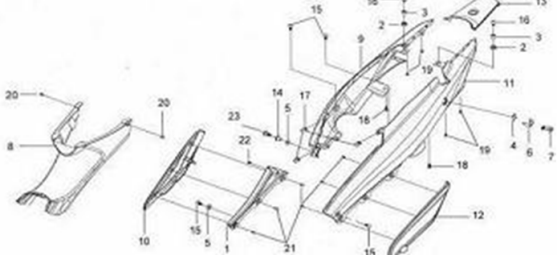
<p>F-10</p> <p align="center">Double seat</p>	<p>F-11</p> <p align="center">Fuel tank</p>	<p>F-12</p> <p align="center">Air cleaner</p>
		
<p>F-13</p> <p align="center">Exhaust muffler</p>	<p>F-14</p> <p align="center">Step bar-Kick starter arm</p>	<p>F-15</p> <p align="center">Main stand-Brake pedal</p>
		
<p>F-16</p> <p align="center">Rear fork- Driven Chain</p>	<p>F-17</p> <p align="center">Rear cushion</p>	<p>F-18</p> <p align="center">Body cover</p>
		

PRICE SHOWN IS PER PIECE. PRODUCT IMAGE PRICES ARE APPROXIMATE GUIDE ONLY.
 PRICES SHOWN ARE SUBJECT TO CHANGE WITHOUT PRIOR NOTICE.

CÁC BỘ PHẬN CỦA KHUNG SUỒN
CONTENTS - FRAME GROUP

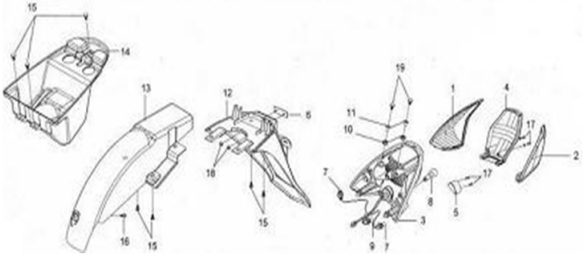
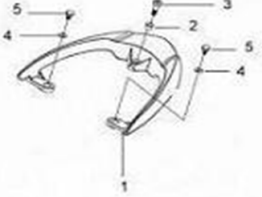
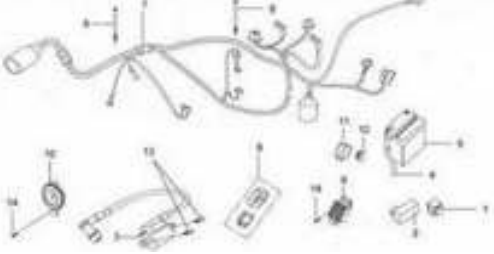
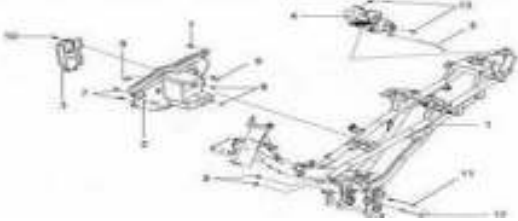
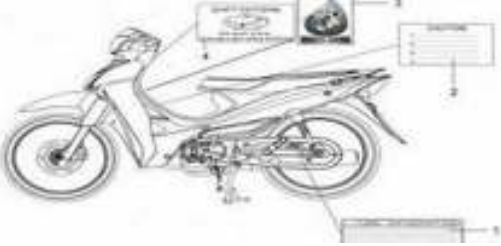
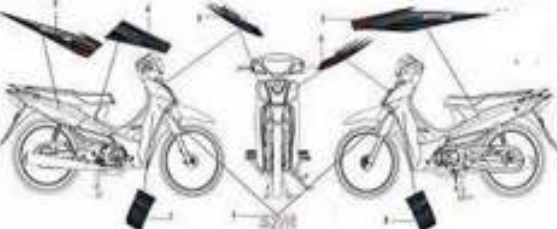
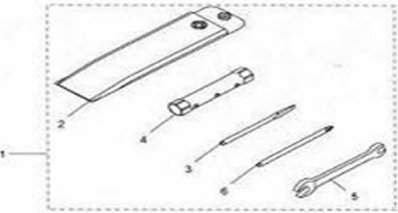
<p>F-19 Rear fender-Tail light</p>	<p>F-20 Rear Carrier</p>	<p>F-21 Wire harness-Battery</p>
		
<p>F-22 Frame body</p>	<p>F-23 Caution-Mark label</p>	<p>F-24 Stripe (Type 1, 2)</p>
		
<p>F-25 Tool ass'y</p>		
		

PRICE SHOWN IS PER PIECE. PRODUCT IMAGE PRICES ARE APPROXIMATE GUIDE ONLY.
 PRICES SHOWN ARE SUBJECT TO CHANGE WITHOUT PRIOR NOTICE.

E-01

NÁP ĐẦU XI LẠNH
CYLINDER HEAD COVER

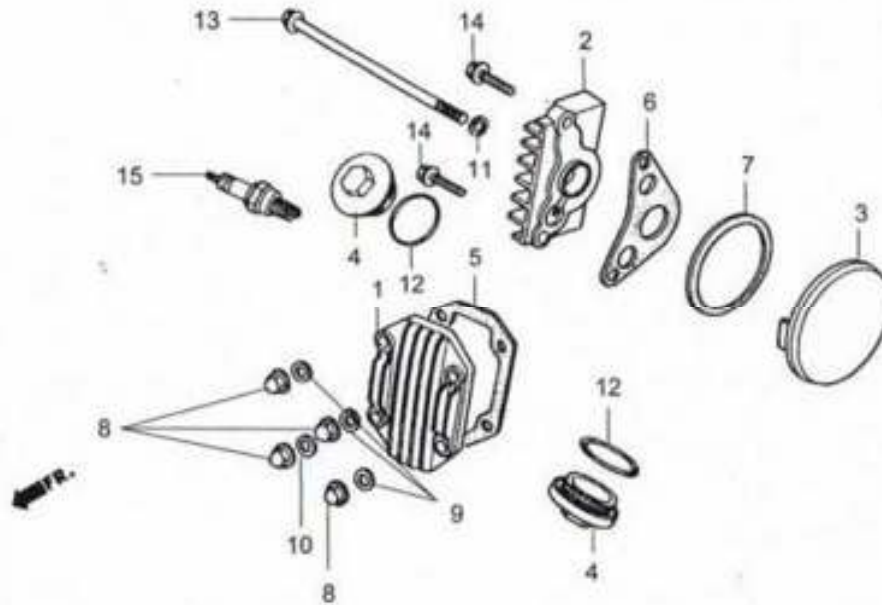

No.	VMEP CODE	(RM) SELLING PRICE	Description	No.	Remark
1	12301-A01-A000	11.20	Cylinder Head Cover	1	
2	12331-A01-A000	11.20	R. Cylinder Head Side Cover	1	
3	12341-A04-A000	11.20	L. Cylinder Head Side Cover	1	
4	12361-M9Q-0000	8.20	Tappet Adjusting Hold Cap	2	
5	12391-VN7-0000	2.60	Cylinder Head Cover Gasket	1	
6	12394-VN7-0000	0.70	R. Cylinder Head Cover Gasket	1	
7	12395-VN7-0000	1.00	L. Cylinder Head Cover Gasket	1	
8	90201-VA2-0002	1.10	Cap Nut 7 mm	4	
9	90442-VA2-0000	0.70	Sealing Washer 7 mm	3	
10	90443-VA2-0000	0.70	Sealing Washer A 7 mm	1	
11	90461-VA2-0001	0.70	Sealing Washer 6.5x12	1	
12	91302-M9Q-0000	0.60	O-Ring 30.8x3.2	2	
13	95701-06110-00	1.20	Flange Bolt 6x110	1	
14	96001-06025-00	0.70	Sh. Flange Bolt 6x25	2	
15	AC-1201-0001	8.30	Spark Plug C6HSA (NGK)	1	

PRICE SHOWN IS PER PIECE. PRODUCT IMAGE PRICES ARE APPROXIMATE GUIDE ONLY.
PRICES SHOWN ARE SUBJECT TO CHANGE WITHOUT PRIOR NOTICE.

E-02

CỤM ĐẦU XI LẠNH
CYLINDER HEAD ASS'Y

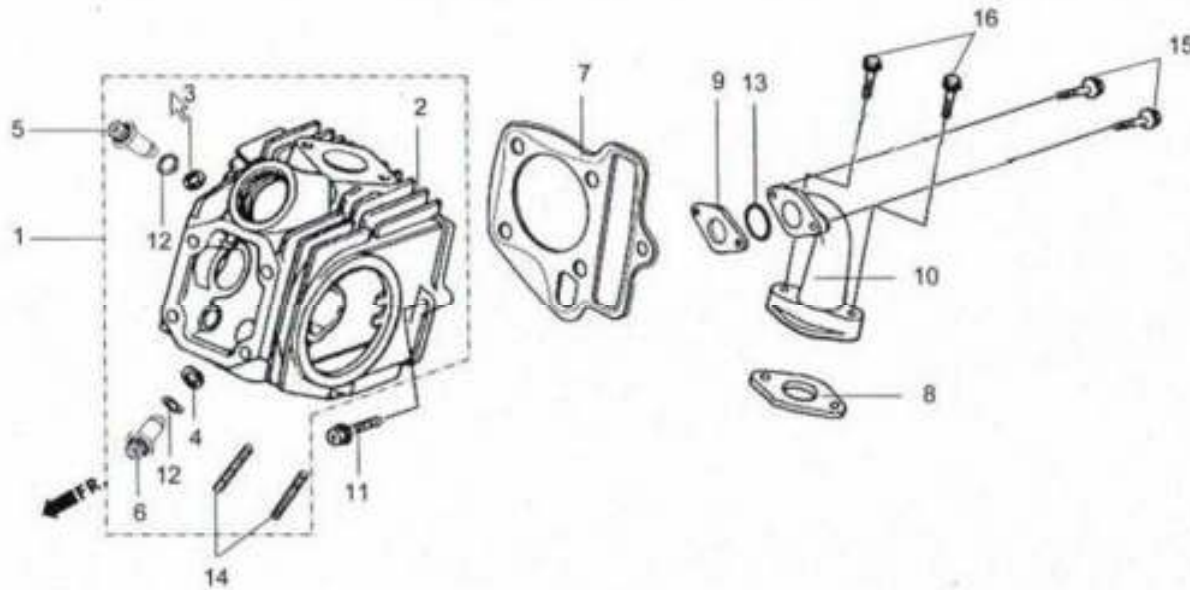

No.	VMEP CODE	(RM) SELLING PRICE	Description	No.	Remark
1	1220A-A04-A002	312.70	Cylinder Head Ass'y	1	
2	12200-SA5-0001-VN	281.40	Cylinder Head Comp.	1	
3	12225-VA2-3002	13.70	Inlet Valve Seat	1	
4	12226-VA2-3002	13.70	Exhaust Valve Seat	1	
5	12237-GB4-6812	9.80	Inlet Valve Guide	1	
6	12245-GB4-6812	9.80	Exhaust Valve Guide	1	
7	12251-VA2-0001	9.90	Cylinder Head Gasket	1	
8	16201-VN7-0000	0.70	Carburator Insulator Gasket	1	
9	16211-A01-A000	2.20	Carburetor Insulator	1	
10	17110-SM1-0000-VN	22.20	Inlet Pipe	1	
11	90081-VA2-0000	1.90	Special Flange Bolt 6x23	1	
12	91305-028-1583	1.00	O-Ring 9x1.6 mm	2	
13	91308-M9Q-0000	1.60	O-Ring 25x2.4 mm	1	
14	92700-A02-0001	1.00	Stud Bolt 6x32 mm	2	
15	96001-06025-00	0.70	Sh. Flange Bolt 6x25	2	
16	96001-06028-07	0.70	Sh. Flange Bolt 6x28	2	

PRICE SHOWN IS PER PIECE. PRODUCT IMAGE PRICES ARE APPROXIMATE GUIDE ONLY.
PRICES SHOWN ARE SUBJECT TO CHANGE WITHOUT PRIOR NOTICE.

E-03

CỐT CAM-XU PÁP CAM SHAFT-VALVE

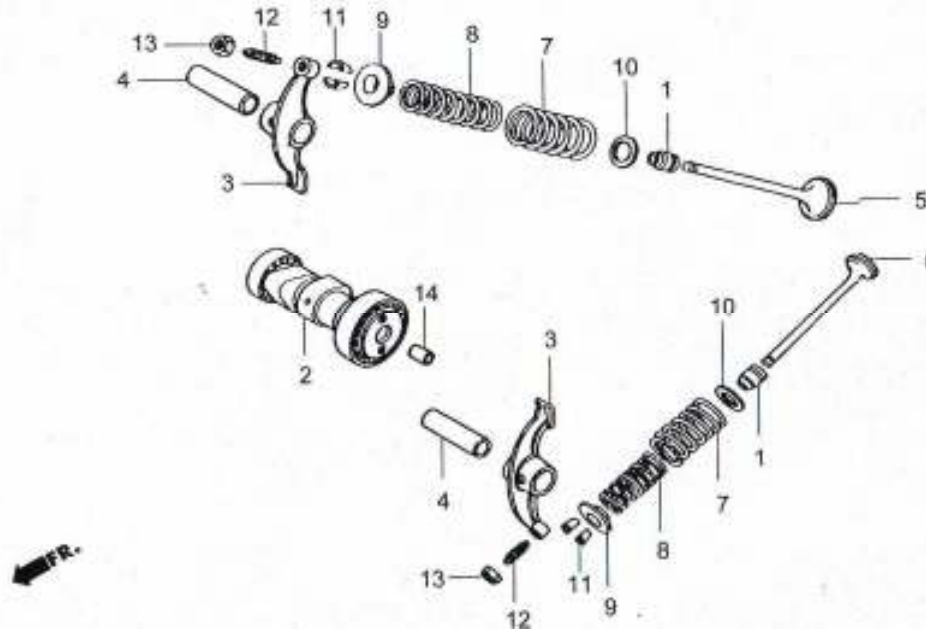

No.	VMEP CODE	(RM) SELLING PRICE	Description	No.	Remark
1	12209-H6B-0000	6.70	Valve Stem Seal	2	
2	14100-VA2-0003	125.80	Cam Shaft Comp.	1	14100-A01-A000
3	14431-M8Q-0000	46.90	Valve Rocker Arm	2	
4	14451-M8Q-0000	7.00	Rocker Arm Shaft	2	
5	14711-VA2-0001	14.40	Inlet Valve	1	
6	14721-VA2-0001	26.70	Exhaust Valve	1	
7	14751-M8Q-0000	6.20	Valve Outer Spring	2	
8	14761-M8Q-0000	5.40	Valve Inner Spring	2	
9	14771-A01-A000	5.40	Valve Spring Retainer	2	
10	14775-M9Q-0000	0.80	Valve Spring Outer Seat	2	
11	14781-A01-A000	2.40	Valve Cotter	4	
12	90012-M9Q-0000	2.20	Tappet Adjusting Screw	2	
13	90206-001-0007	1.60	Tappet Adjusting Screw Nut	2	
14	90702-M8Q-0000	1.00	Dowel Pin 8x12	1	

PRICE SHOWN IS PER PIECE. PRODUCT IMAGE PRICES ARE APPROXIMATE GUIDE ONLY.
PRICES SHOWN ARE SUBJECT TO CHANGE WITHOUT PRIOR NOTICE.

E-04

XÍCH CAM-CĂNG XÍCH CAM CAM CHAIN-TENSIONER

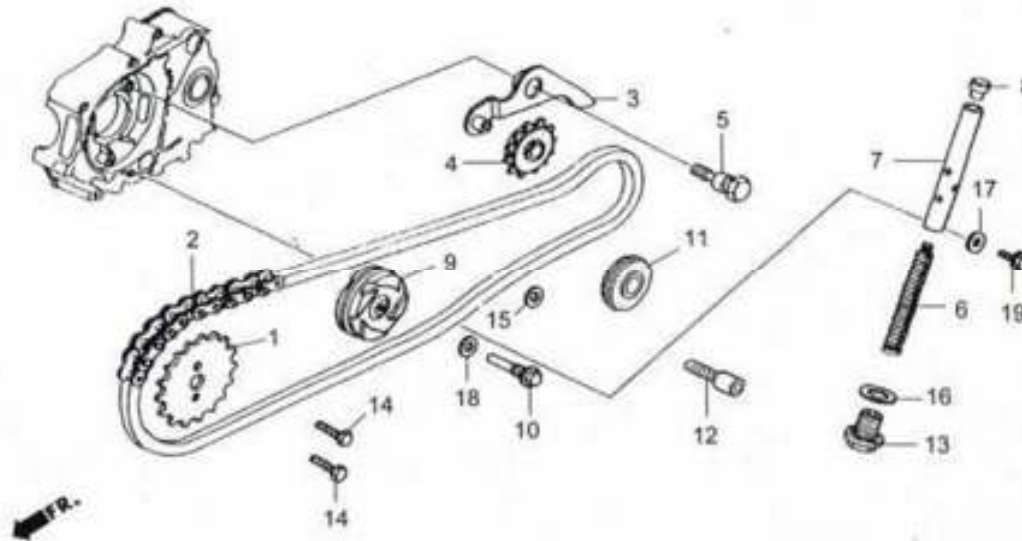

No.	VMEP CODE	(RM) SELLING PRICE	Description	No.	Remark
1	14321-VA2-0001	9.30	Cam Sprocket (32T)	1	
2	1CK 25H X 90L	14.10	Cam Chain (90L)	1	
3	14500-A01-A001-L1	7.80	Cam Chain Tensioner Arm Comp.	1	
4	14502-M8Q-0000	7.80	Cam Chain Tensioner Roller	1	
5	14531-A08-0000	3.60	Cam Chain Tensioner Pivot	1	
6	14541-M8Q-0100	0.80	Cam Chain Tensioner Spring	1	
7	14550-M8Q-0000	14.40	Tensioner Push Rod Comp.	1	
8	14566-A08-0101	1.10	Tensioner Push Rod Head	1	
9	14610-VA2-0001	10.20	Cam Chain Guide Roller Comp. (B)	1	
10	14615-VA2-0000	1.80	Roller Guide Pin	1	
11	14670-VA2-0001	12.30	Chain Guide Roller Comp. (A)	1	
12	14675-VA2-0000	1.20	Cam Chain Guide Roller Bolt	1	
13	90081-035-0006	1.90	Sealing Bolt 14 mm	1	
14	90083-A08-0000	0.70	Knock Bolt 5 mm	2	
15	90405-VA2-0000	0.70	Plain Washer 6.5x16x2.6	1	
16	90441-M8Q-0000	0.70	Seal Washer 14 mm	1	
17	90461-VA2-0001	0.70	Sealing Washer 6.5x12 mm	1	
18	90481-035-0001	0.70	Washer 8 mm	1	
19	95701-06018-07	0.40	Flange Bolt 6x18	1	

PRICE SHOWN IS PER PIECE. PRODUCT IMAGE PRICES ARE APPROXIMATE GUIDE ONLY.
PRICES SHOWN ARE SUBJECT TO CHANGE WITHOUT PRIOR NOTICE.

E-05

XI LANH CYLINDER

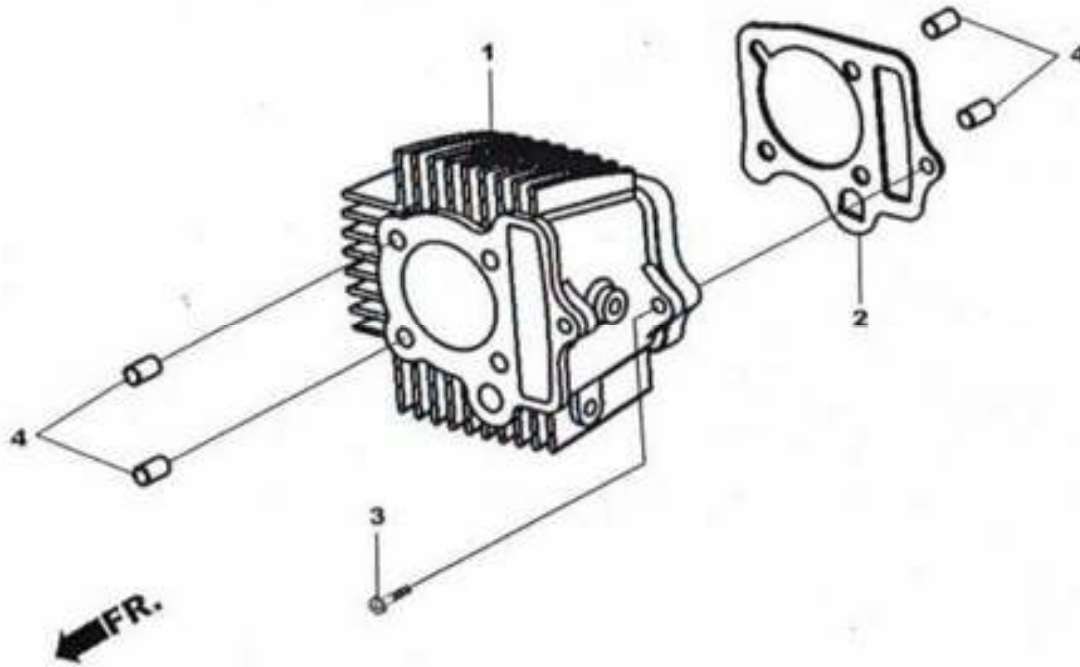

No.	VMEP CODE	(RM) SELLING PRICE	Description	No.	Remark
1	12101-A04-A000	146.60	Cylinder	1	
2	12191-VN7-0000	2.20	Cylinder Gasket	1	
3	90081-VA2-0000	1.90	Special Flange Bolt 6x23	1	
4	90702-M8Q-0000	1.00	Dowel Pin 8x14	4	

PRICE SHOWN IS PER PIECE. PRODUCT IMAGE PRICES ARE APPROXIMATE GUIDE ONLY.
PRICES SHOWN ARE SUBJECT TO CHANGE WITHOUT PRIOR NOTICE.

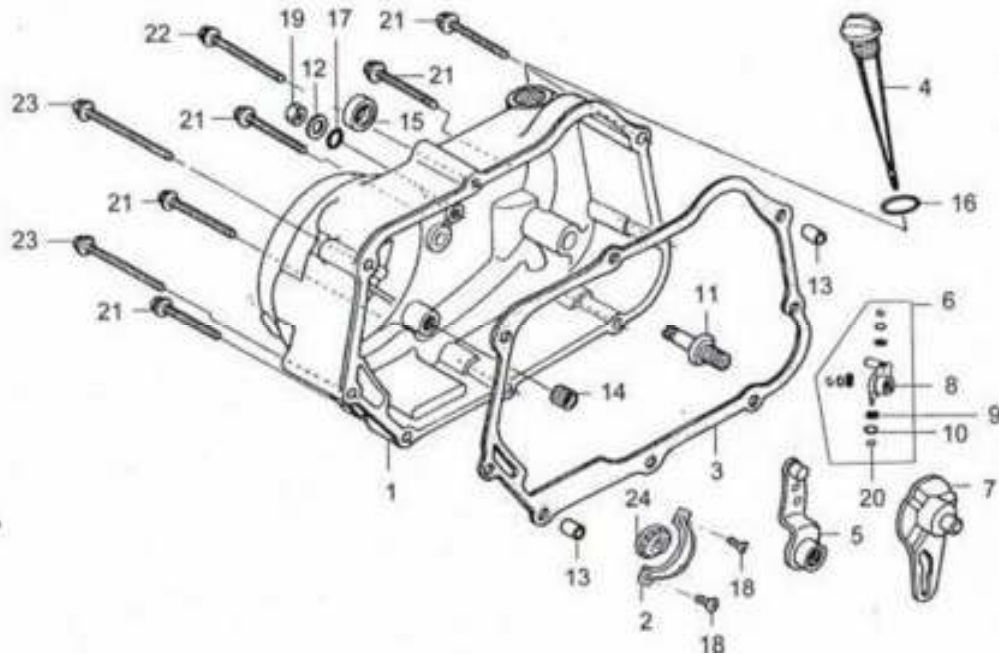

E-06

NẮP MÁY BÊN PHẢI RIGHT CRANK CASE COVER

No.	VMEP CODE	(RM) SELLING PRICE	Description	STT No.	Remark
1	11330-VA2-0000	109.40	R. Crank Case Cover Comp.	1	
2	11338-M3G-0003	2.00	Bearing Retainer A	1	
3	11394-VN7-0000	3.90	R. Crank Case Cover Gasket	1	
4	1565A-VA1-0000	4.40	Oil Level Gauge	1	Change from 1565A-VA2-0000
5	22810-VA2-0000	16.80	Clutch Lever Comp.	1	
6	22820-M3G-0001	30.00	Clutch Lifter Boss Ass'y	1	(PARENT PART)
7	22820-A01-A000	4.70	Clutch Lifter Plate Comp.	1	
8	22821-M3G-0001	18.70	Clutch Lifter Boss	1	child part, parent part is 22820-M3G-0000
9	22822-M3G-0000(X)		Clutch Lifter Boss Roller	3	please order parent part,E06-6,22820-M3G-0001
10	22823-M3G-0000(X)		Clutch Lifter Boss Washer	3	please order parent part,E06-6,22820-M3G-0001
11	22864-VA2-0000	6.70	Clutch Adjusting Bolt	1	
12	90485-A08-0001	0.70	Washer 8 mm	1	
13	90702-M8Q-0000	1.00	Dowel Pin 8x12	2	
14	91021-148-0040	11.20	Needle Bearing HK 1010	1	
15	91202-VA2-0000	2.20	Oil Seal 13.7x24x5	1	
16	91307-B06-0000	1.60	O-Ring 18x3 mm	1	

PRICE SHOWN IS PER PIECE. PRODUCT IMAGE PRICES ARE APPROXIMATE GUIDE ONLY.
PRICES SHOWN ARE SUBJECT TO CHANGE WITHOUT PRIOR NOTICE.

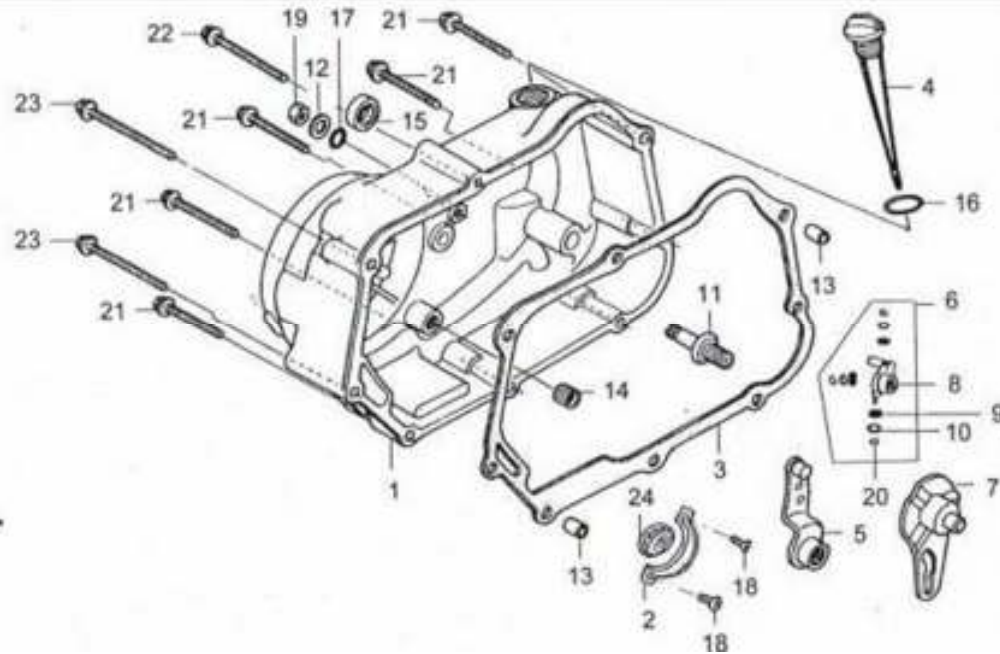

E-06

NẮP MÁY BÊN PHẢI RIGHT CRANK CASE COVER

No.	VMEP CODE	(RM) SELLING PRICE	Description	No.	Remark
17	91312-A01-A001	0.40	O-Ring 7.8 mm	1	
18	93600-06010-0A	0.70	FLAT SCREW 6*10	2	
19	94030-08000-00	1.10	Hex Nut 8 mm	1	
20	94504-03018(X)		E-Ring 3 mm	3	please order parent part,E06-6,22820-M3G-0001
21	96001-06040-00	0.80	Sh. Flange Bolt 6x40	5	
22	96001-06065-00	1.80	Sh. Flange Bolt 6x65	1	
23	96001-06080-00	1.90	Sh. Flange Bolt 6x80	2	
24	96140-60010-00	8.00	Radial Ball Bearing 6001LU (CJB)	1	

PRICE SHOWN IS PER PIECE. PRODUCT IMAGE PRICES ARE APPROXIMATE GUIDE ONLY.
PRICES SHOWN ARE SUBJECT TO CHANGE WITHOUT PRIOR NOTICE.

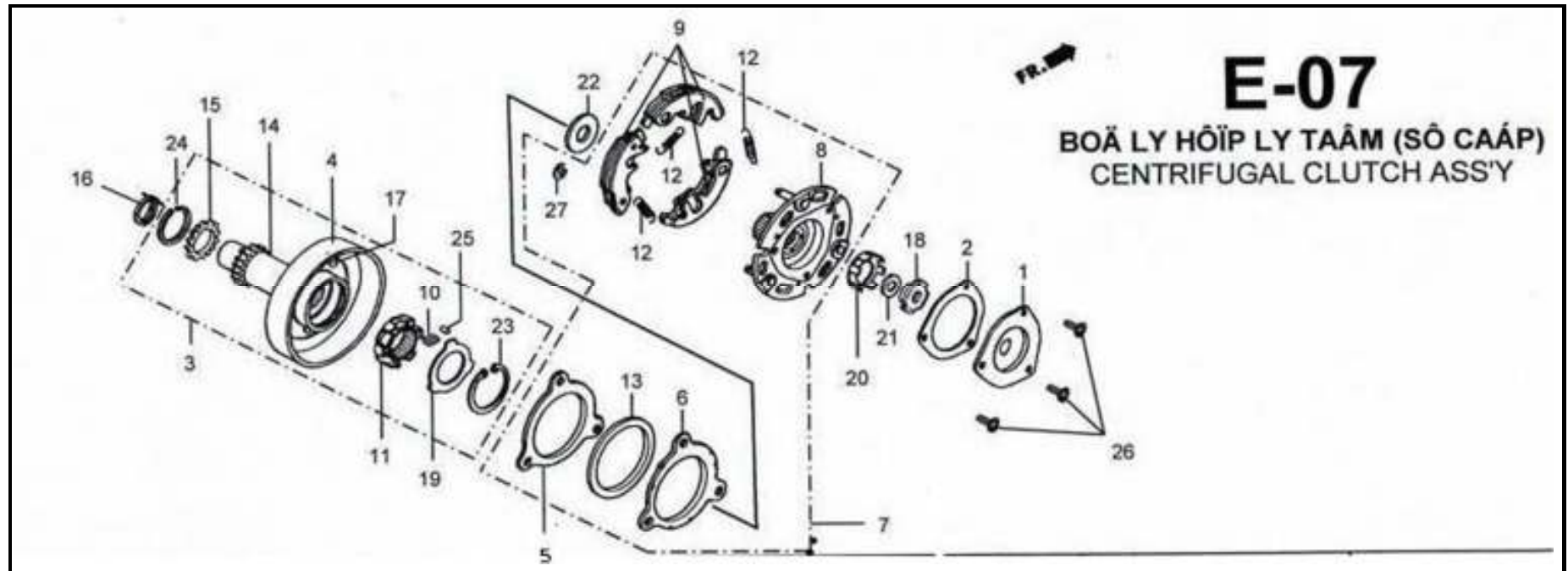

No.	VMEP CODE	(RM) SELLING PRICE	Description	STT No.	Remark
1	15436-M3G-0100	7.20	Oil Filer Cover	1	
2	15439-VA2-0000	1.20	Oil Filter Cover Gasket	1	
3	2210B-A05-0001-VN	74.90	Centrifugal Clutch Outer Set	1	
4	22101-A05-3001(X)		Centrifugal Clutch Outer	1	please order parent part, 22100-A05-0000
5	22111-M3G-0100	11.20	Centrifugal Clutch Plate A	1	
6	22112-M3G-0100	11.20	Centrifugal Clutch Plate B	1	
7	22300-A05-0000-VN	112.30	Clutch Drive Plate Ass'y	1	
8	22350-M3G-0101	29.70	Clutch Drive Plate Comp.	1	
9	22530-M3G-0101	34.00	Clutch Weight	3	
10	22606-M3G-0000	0.70	One Way Retainer Spring	6	
11	22630-M3G-0001	26.10	One Way Clutch Inner Comp.	1	
12	22641-M3G-0100	2.20	Clutch Spring B	3	
13	23117-M3G-0100	5.50	Spring Plate	1	
14	23120-A05-0000(X)		Primary Drive Gear	1	please order parent part, 22100-A05-0000
15	23122-A05-0000(X)		Sub Gear	1	please order parent part, 22100-A05-0000
16	23124-VA2-0001	3.70	Sub Gear Spring	1	

PRICE SHOWN IS PER PIECE. PRODUCT IMAGE PRICES ARE APPROXIMATE GUIDE ONLY.
 PRICES SHOWN ARE SUBJECT TO CHANGE WITHOUT PRIOR NOTICE.

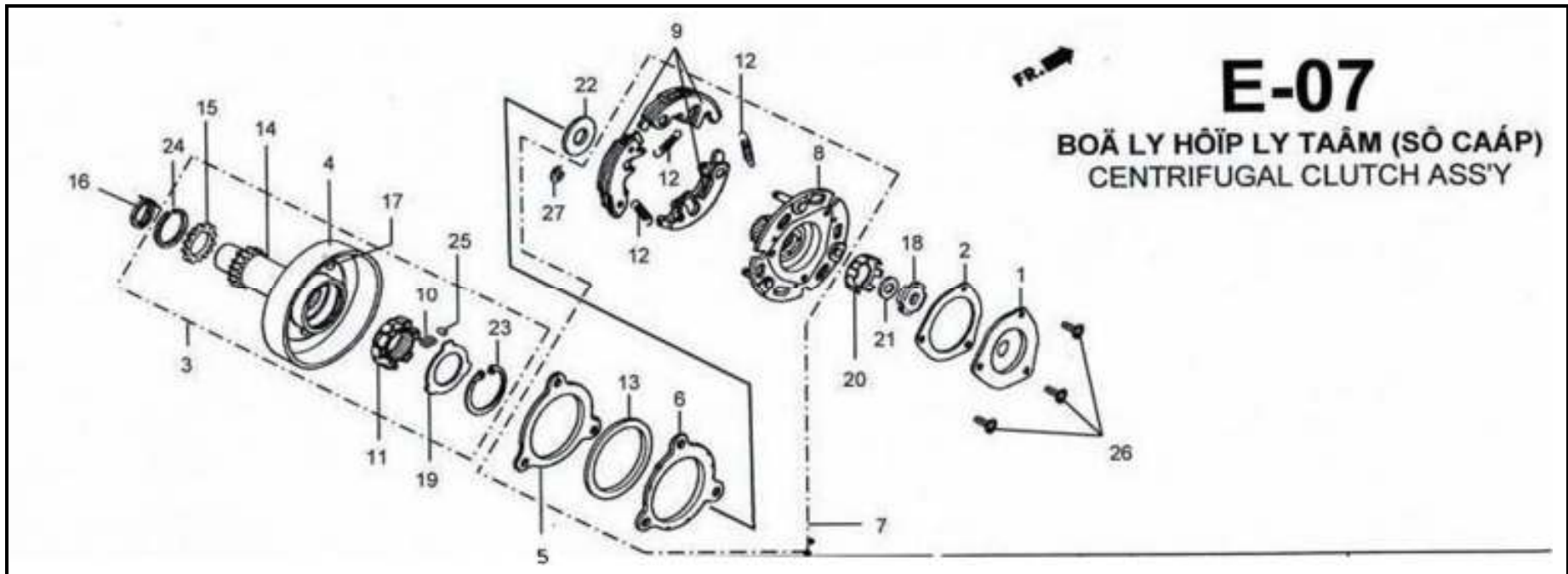

No.	VMEP CODE	(RM) SELLING PRICE	Description	No.	Remark
17	23126-A05-3000(X)		Rivet 5 mm	3	please order parent part, 22100-A05-0000
18	90231-M8Q-0000	1.90	Lock Nut 14 mm	1	
19	90401-M3G-0000	0.60	Washer 30x45x0.8	1	
20	90431-M3G-0001	1.10	Lock Washer 14 mm	1	
21	90432-SB1-0000	1.10	Lock Washer B 14 mm	1	
22	90434-M3G-0000	0.70	Washer 17x23x3	1	
23	90455-M3G-0000	1.60	Cir-Clip In 45 mm	1	
24	90603-A05-0000(X)		Set Ring 23 mm	1	please order parent part, 22100-A05-0000
25	91101-M3G-0000	1.60	Roller 5x8	6	
26	93500-05008-OA	0.40	Pan Screw 5x8	3	
27	94540-07010	1.30	E-Ring 7 mm	3	

PRICE SHOWN IS PER PIECE. PRODUCT IMAGE PRICES ARE APPROXIMATE GUIDE ONLY.
 PRICES SHOWN ARE SUBJECT TO CHANGE WITHOUT PRIOR NOTICE.

E-08

BỘ LY HỢP MA SÁT (THỨ CẤP) CLUTCH OUTER ASS'Y

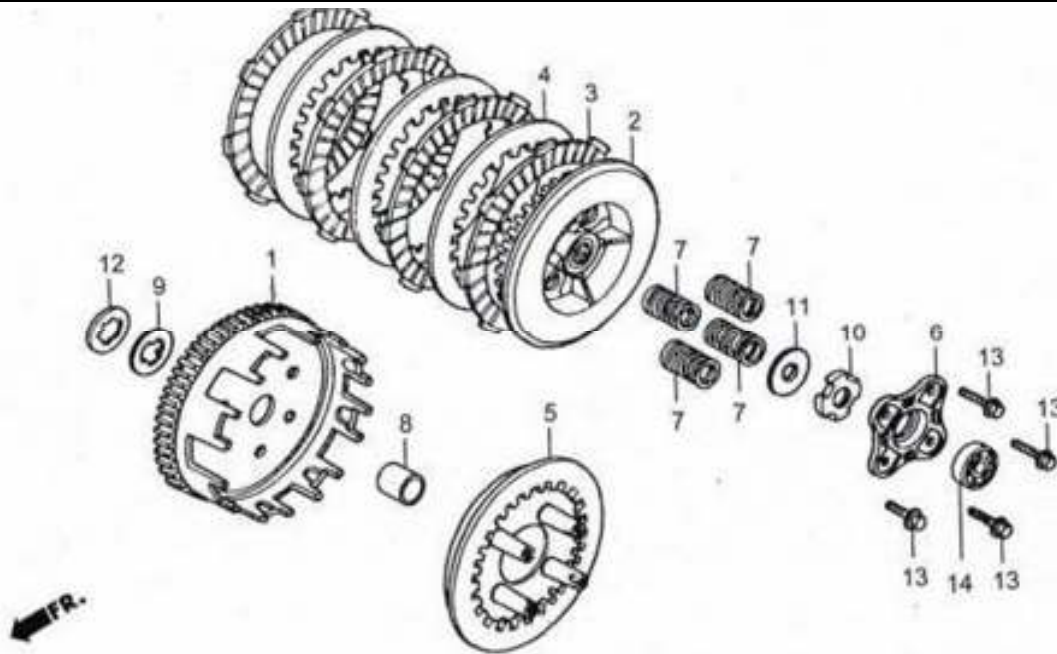

STT No.	VMEP CODE	(RM) SELLING PRICE	Description	No.	Remark
1	2200A-A05-0004-VN	180.90	Clutch Outer Set	1	
2	22121-A05-0000	12.00	Clutch Center	1	
3	22201-107-0000-A	4.10	Clutch Friction Disk	4	
4	22311-107-0002	8.60	Clutch Plate	3	
5	22351-A05-0000	30.00	Clutch Pressure Plate	1	
6	22361-A05-0002	6.40	Clutch Lifter Plate	1	
7	22401-M3G-0001	2.00	Clutch Spring A	4	
8	22100-A05-0000	74.90	Clutch Center Guide	1	
9	23217-M3G-0002	0.70	Set Ring 17 mm	1	
10	90231-VA2-0000	1.90	Lock Nut 14 mm	1	
11	90432-SB1-0000	1.10	Lock Washer B 14 mm	1	
12	90464-VA2-0000	0.70	Spline Washer 17 mm	1	
13	95701-06022-08	0.70	Flange Bolt 6x22	4	
14	96100-60000-00	15.00	Radial Ball Bearing 6000 (CJB)	1	

PRICE SHOWN IS PER PIECE. PRODUCT IMAGE PRICES ARE APPROXIMATE GUIDE ONLY.
PRICES SHOWN ARE SUBJECT TO CHANGE WITHOUT PRIOR NOTICE.

E-09

BỘ BƠM DẦU
OIL PUMP ASS'Y

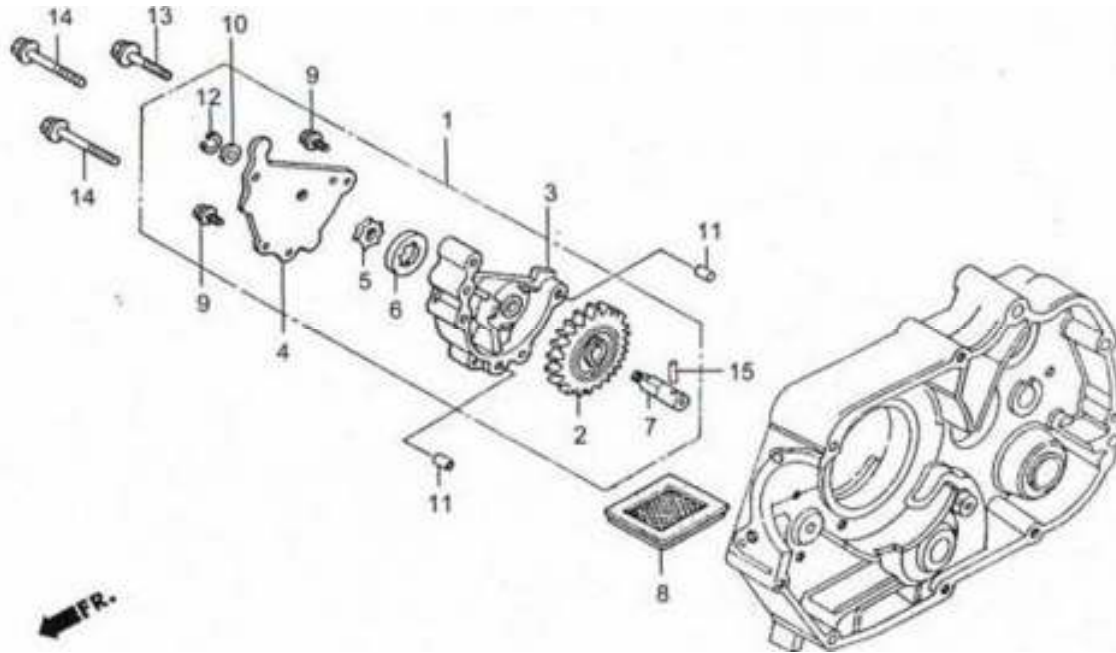

No.	VMEP CODE	(RM) SELLING PRICE	Description	No.	Remark
1	15100-VA2-0004	48.80	Oil Pump Ass'y	1	
2	15133-VA2-0001	16.50	Oil Pump Driven Gear	1	
3	15311-VA2-0002	21.50	Oil Pump Body	1	
4	15321-VA2-0002	19.60	Oil Pump Body Cover	1	
5	15331-VA2-0001	9.80	Oil Pump Inner Rotor	1	
6	15332-VA2-0001	9.80	Oil Pump Outer Rotor	1	
7	15382-VA2-0001	35.20	Oil Pump Driver Shaft	1	
8	15421-M8Q-0000	4.30	Oil Filter Screen	1	
9	90002-VA2-0000	0.70	Flange Bolt 5x10	2	
10	90444-VA2-0000	1.10	Thrust Washer 6 mm	1	
11	90702-M8Q-0000	1.00	Dowel Pin 8x12	2	
12	94540-05018	0.70	E-Ring 5 mm	1	
13	95701-06035-00	0.80	Flange Bolt 6x35	1	
14	95701-06040-00	0.80	Flange Bolt 6x40	2	
15	96220-30158	0.70	Roller 3x15.8	1	

PRICE SHOWN IS PER PIECE. PRODUCT IMAGE PRICES ARE APPROXIMATE GUIDE ONLY.
PRICES SHOWN ARE SUBJECT TO CHANGE WITHOUT PRIOR NOTICE.

E-10

NẮP MÁY BÊN TRÁI LEFT CRANK CASE COVER

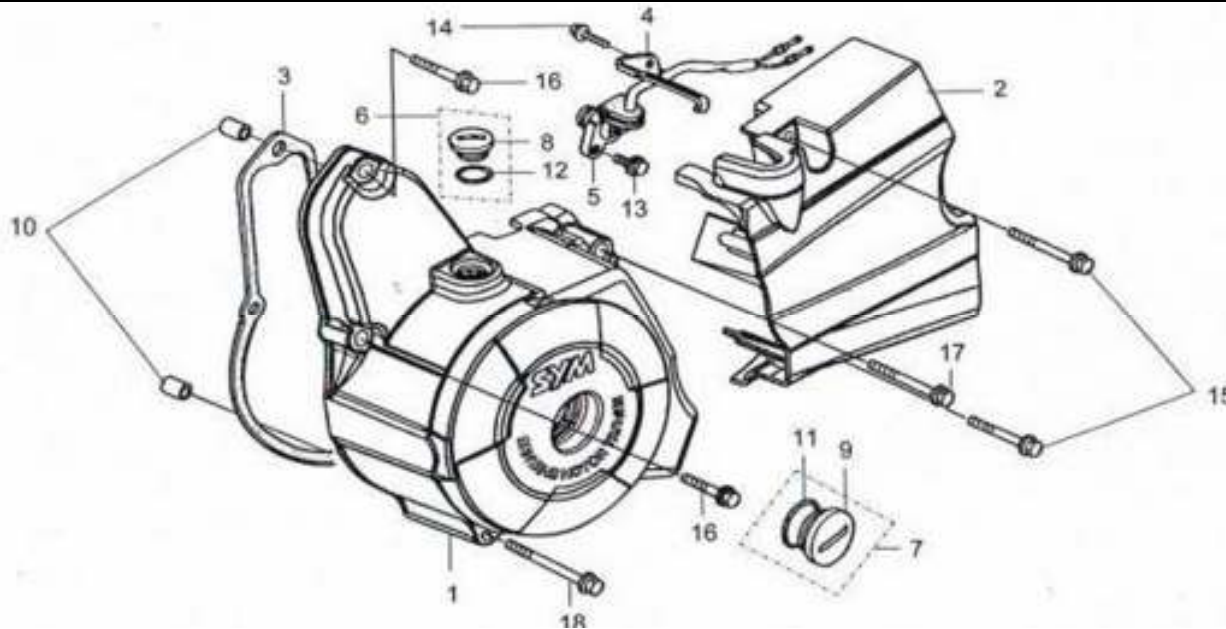

No.	VMEP CODE	(RM) SELLING PRICE	Description	No.	Remark
1	11341-VA2-0000	83.00	L. Crank Case Cover Comp.	1	
2	11360-VA2-9000	31.40	L. Crank Case Rear Cover	1	
3	11395-VN7-0000	3.20	L. Crank Case Cover Gasket	1	
4	32961-VA2-0000	1.80	A. C. G. Cord Clamper B	1	
5	3575A-VA2-0002	17.20	Change Switch Ass'y	1	parent part 3500T-VA2-0001
6	9008A-M8Q-0000	5.10	A.C.G. Cap Ass'y 14 mm	1	(PARENT PART)
7	9008B-M8Q-0000	7.50	A.C.G. Cap Ass'y 30 mm	1	(PARENT PART)
8	9008A-A01-A000(X)		A.C.G. Cap 14 mm	1	please order parent part,E10-6, 9008A-M8Q-0000
9	90087-A01-A000(X)		A.C.G. Cap 30 mm	1	please order parent part,E10-7,9008B-M8Q-0000
10	90702-M8Q-0000	1.00	Dowel Pin 8x12	2	
11	91308-VA2-0000(X)		O-Ring 27x2.0	1	please order parent part,E10-7,9008B-M8Q-0000
12	91303-M2Q-0000	1.10	O-Ring 13.8x2.5	1	(child part, parent part refer 9008A-M8Q-000,
13	96001-06012-08	0.80	Sh. Flange Bolt 6x12	1	parent part 3500T-VA2-0001
14	96001-06016-00	0.70	Sh. Flange Bolt 6x16	1	
15	96001-06028-07	0.70	Sh. Flange Bolt 6x28	2	
16	96001-06032-08	0.70	Sh. Flange Bolt 6x32	2	
17	96001-06050-00	0.80	Sh. Flange Bolt 6x50	1	
18	96001-06070-08	1.90	Sh. Flange Bolt 6x70	1	

PRICE SHOWN IS PER PIECE. PRODUCT IMAGE PRICES ARE APPROXIMATE GUIDE ONLY.
PRICES SHOWN ARE SUBJECT TO CHANGE WITHOUT PRIOR NOTICE.

E-11

**BỘ PHÁT ĐIỆN
GENERATOR**

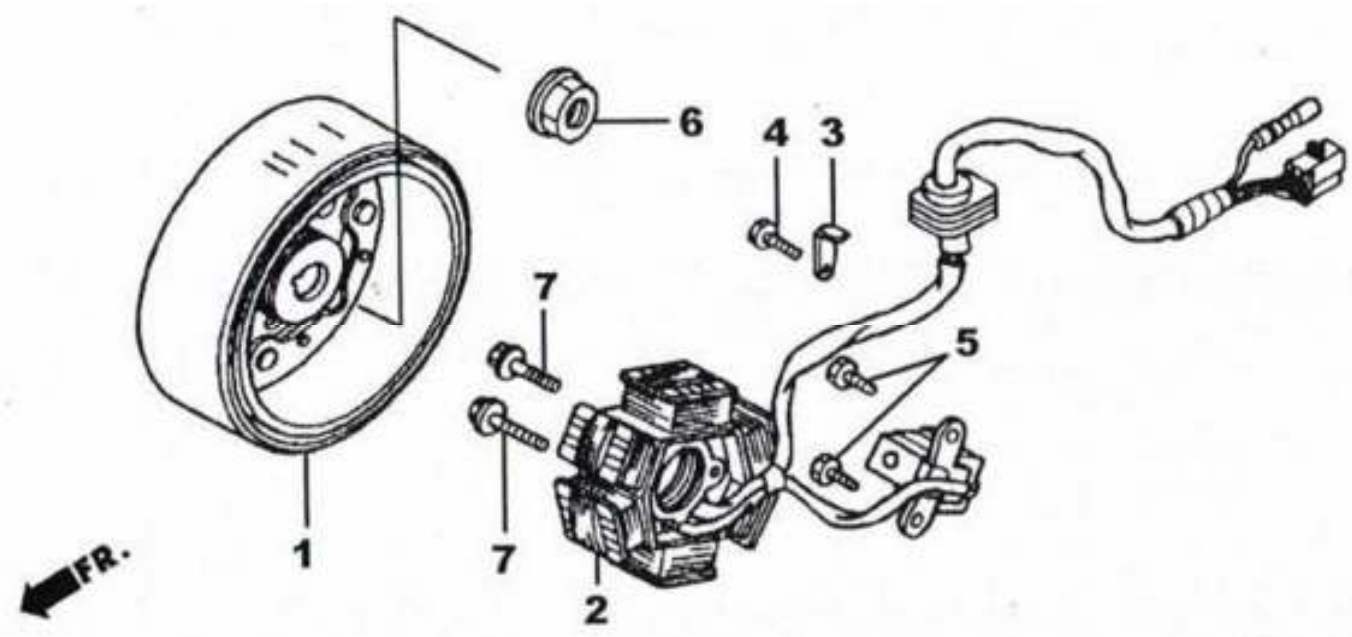

No.	VMEP CODE	(RM) SELLING PRICE	Description	No.	Remark
1	3111A-VA2-0003	112.30	Flywheel Comp.	1	
2	31120-VA2-0003	56.20	Stator Comp.	1	
3	31141-VA2-0000	0.80	A.C Generator Cord Clamber	1	
4	93500-05006-0A	0.40	Pan Screw 5x6	1	
5	93500-05010-0A	0.40	Pan Screw 5x10	2	
6	94050-12000	2.40	Flange Nut 12 mm	1	
7	96001-06022-02	0.70	Sh. Flange Bolt 6x22	2	

PRICE SHOWN IS PER PIECE. PRODUCT IMAGE PRICES ARE APPROXIMATE GUIDE ONLY.
 PRICES SHOWN ARE SUBJECT TO CHANGE WITHOUT PRIOR NOTICE.

E-12

LY HỢP KHỞI ĐỘNG STARTING CLUTCH

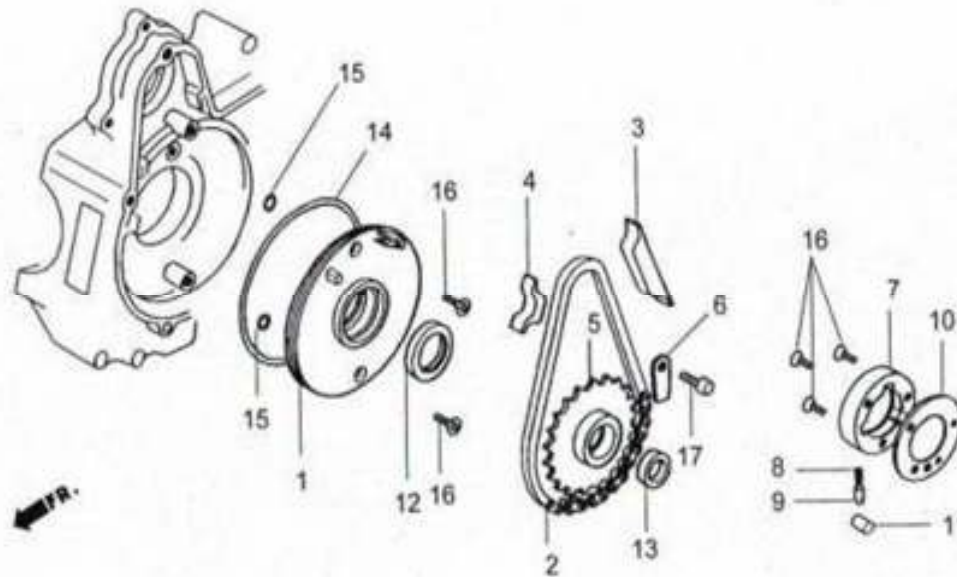

No.	VMEP CODE	(RM) SELLING PRICE	Description	No.	Remark
1	11321-A01-A000-VN	10.30	Oil Separate Cover	1	
2	1CS 25H X 62L	8.80	Starting Chain (62L)	1	
3	28102-M8Q-0000	3.50	Starter Chain Guide	1	
4	28103-M8Q-0000	2.90	Starter Chain Protector	1	
5	28110-A01-A001	47.60	Starting Sprocket Comp.	1	
6	28117-A05-0000-VN	2.10	Starting Sprocket Set Plate	1	
7	28120-A01-0000	63.60	Starting Clutch Outer	1	
8	28125-M7Q-0001	2.10	Starting Clutch Roller Spring	3	
9	28126-253-0305	4.10	Starting Roller Spring Cap	3	
10	28128-A01-A000-VN	18.20	Starting Cam Side Plate	1	
11	91101-M8Q-0000	2.00	Roller 10x10	3	
12	91201-VA2-0000	3.70	Oil Seal 30x42x4.5	1	
13	91202-A01-0000	3.70	Oil Seal 18.9x30x5	1	
14	91302-VA2-0000	3.00	O-Ring 107x2	1	
15	91318-VA2-0000	0.70	O-Ring 6.5x1.7	2	
16	93600-06016-OA	0.70	Flat Screw 6x16	5	
17	96001-06010-08	0.80	Sh. Flange Bolt 6x10	1	

PRICE SHOWN IS PER PIECE. PRODUCT IMAGE PRICES ARE APPROXIMATE GUIDE ONLY.
PRICES SHOWN ARE SUBJECT TO CHANGE WITHOUT PRIOR NOTICE.

E-13

MÔ-TƠ KHỞI ĐỘNG STARTING MOTOR

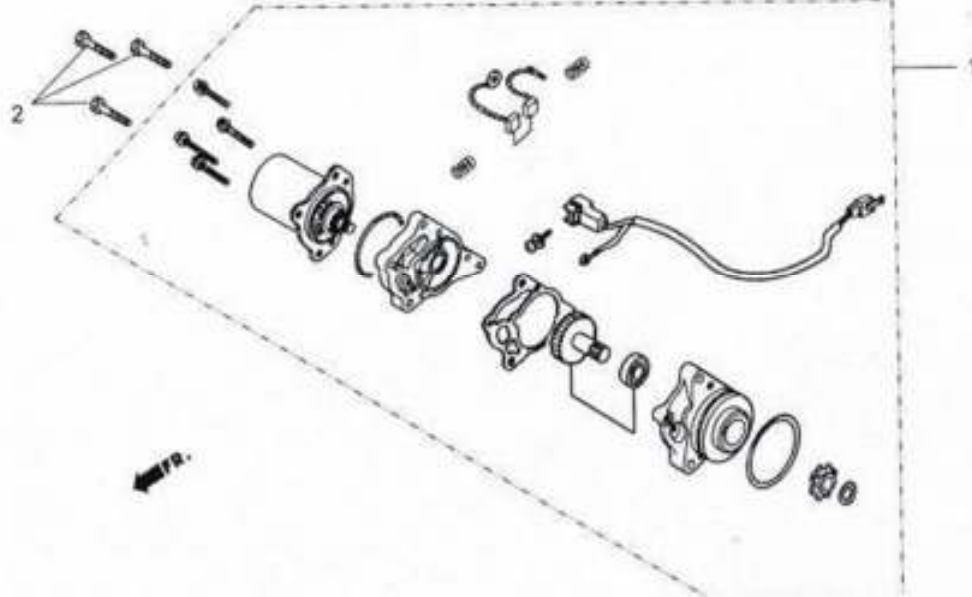

No.	VMEP CODE	(RM) SELLING PRICE	Description	No.	Remark
1	31200-VA2-0003	125.00	Start Motor Ass'y	1	
2	96001-06050-00	0.80	Flange Bolt 6x50	3	

PRICE SHOWN IS PER PIECE. PRODUCT IMAGE PRICES ARE APPROXIMATE GUIDE ONLY.
 PRICES SHOWN ARE SUBJECT TO CHANGE WITHOUT PRIOR NOTICE.

E-14

HỘP TRỤC KHUYU CRANK CASE

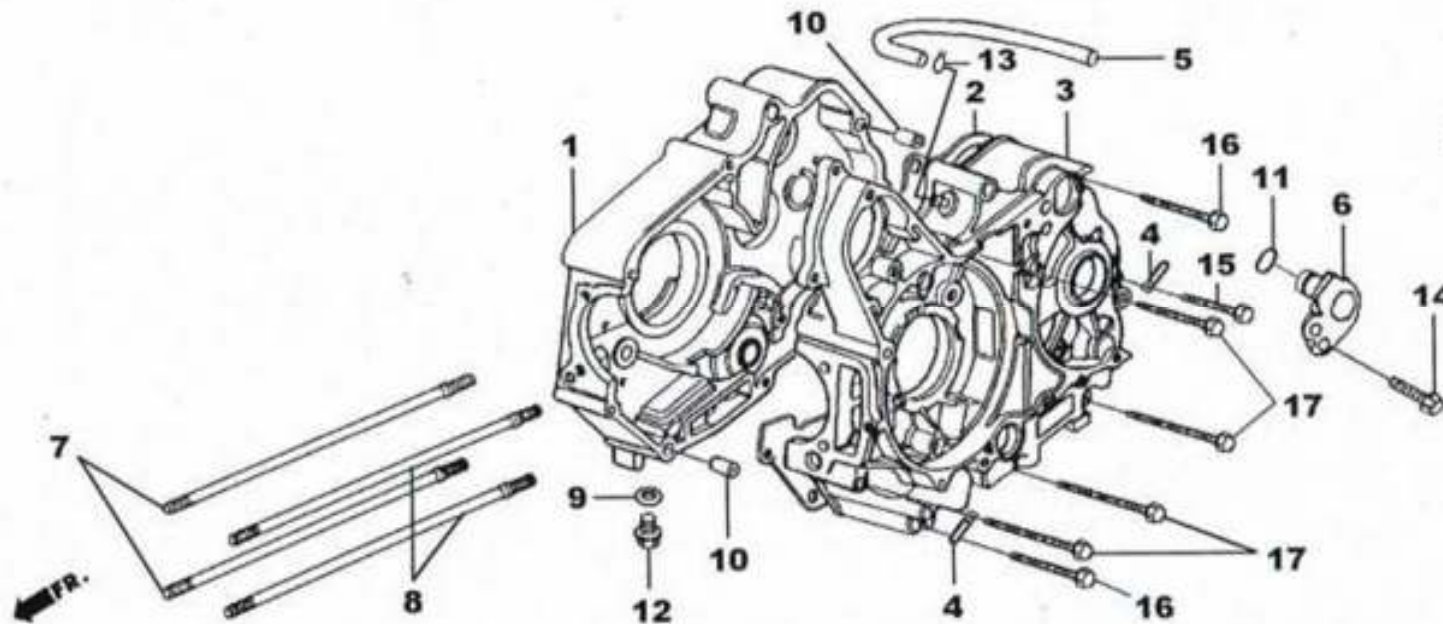

No.	VMEP CODE	(RM) SELLING PRICE	Description	No.	Remark
1	11100-VDA-0002	187.80	R. Crank Case Comp.	1	
2	11191-VN7-0000	4.10	Crank Case Gasket	1	
3	11200-SAB-0000-F2	175.90	L. Crank Case Comp.	1	
4	12342-X01-0000	1.10	Clamp	2	
5	1576A-VA2-0006(X)		Breather Tube	1	please order parent part, 1576A-VA2-0001
6	24331-VA2-0000	4.10	Contact Switch Block	1	parent part 3500T-VA2-0001
7	90031-VA1-0002	4.50	Cylinder Stud Bolt 6x206.5x7	2	
8	90032-VA1-0002	4.50	Cylinder Stud Bolt 6x214.5x7	2	
9	90407-SB1-0000	0.70	Drain Cock Parking 12.5x20	1	
10	90703-HC4-0000	1.40	Dowel Pin 10x14	2	
11	91301-VA2-0000	0.70	O-Ring 22x2	1	
12	92800-12000	2.60	Drain Plug Bolt 12 mm	1	
13	95002-70000(X)		Tube Clip C11	1	please order parent part, 1576A-VA2-0001
14	96001-06025-00	0.70	Sh. Flange Bolt 6x25	1	
15	96001-06050-00	0.80	Sh. Flange Bolt 6x50	1	
16	96001-06060-08	1.80	Sh. Flange Bolt 6x60	2	
17	96001-06065-00	1.80	Sh. Flange Bolt 6x65	4	

PRICE SHOWN IS PER PIECE. PRODUCT IMAGE PRICES ARE APPROXIMATE GUIDE ONLY.
PRICES SHOWN ARE SUBJECT TO CHANGE WITHOUT PRIOR NOTICE.

E-15

BỘ TRỤC KHUỖU-PISTON CRANK SHAFT-PISTON

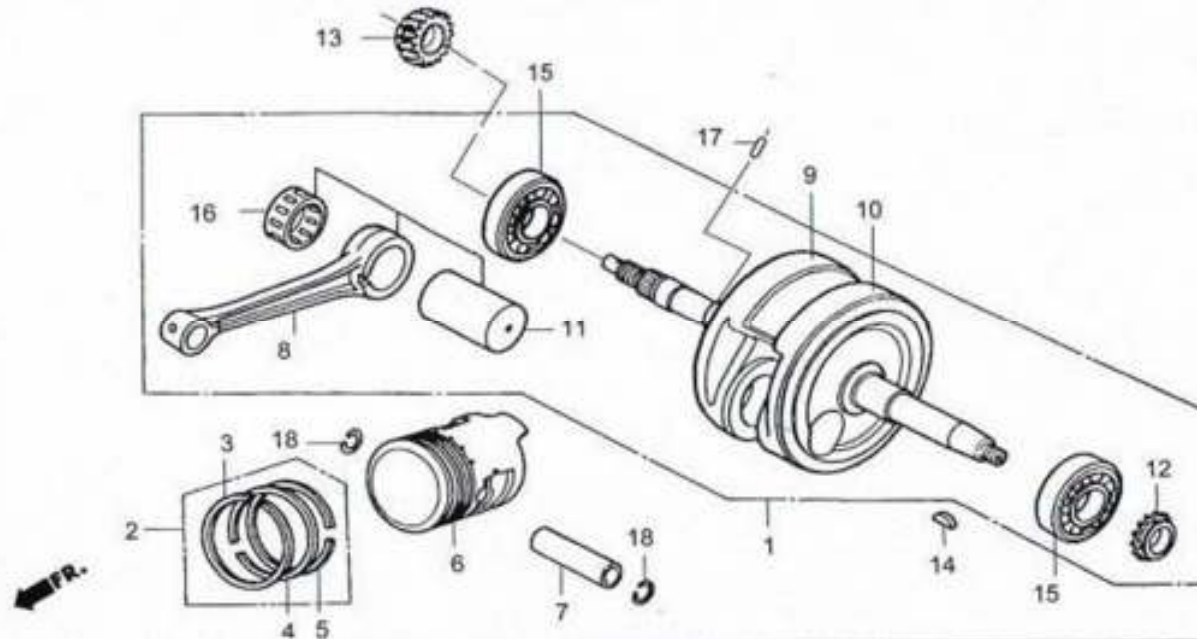

No.	VMEP CODE	(RM) SELLING PRICE	Description	No.	Remark
1	13000-VA1-0002	359.40	Crank Shaft Comp.	1	(PARENT PART)
2	13010-VA2-0000	27.00	Piston Ring Set (STD.)	1	
	13012-VA2-3050	28.80	Piston Ring Set (0.25)	1	
	13013-VA2-3050	30.70	Piston Ring Set (0.50)	1	
	13014-VA2-3050	32.60	Piston Ring Set (0.75)	1	
	13015-VA2-3050	34.50	Piston Ring Set (1.00)	1	
3	13121-VA2-000		Piston Top Ring	1	
4	13131-A31-000		Piston 2nd Ring	1	
5	13141-VA2-000		Piston Oil Ring	1	
6	13101-VA2-0000	30.00	Piston (STD.)	1	
	13102-VA2-3050	31.90	Piston (0.25)	1	
	13103-VA2-3050	33.70	Piston (0.50)	1	
	13104-VA2-3050	35.60	Piston (0.75)	1	
	13105-VA2-3050	37.50	Piston (1.00)	1	
7	13111-A04-A000	4.10	Piston Pin	1	
8	13201-VA1-0001	58.60	Connecting Rod	1	

PRICE SHOWN IS PER PIECE. PRODUCT IMAGE PRICES ARE APPROXIMATE GUIDE ONLY.
PRICES SHOWN ARE SUBJECT TO CHANGE WITHOUT PRIOR NOTICE.

E-15

BỘ TRỤC KHUỖU-PISTON CRANK SHAFT-PISTON

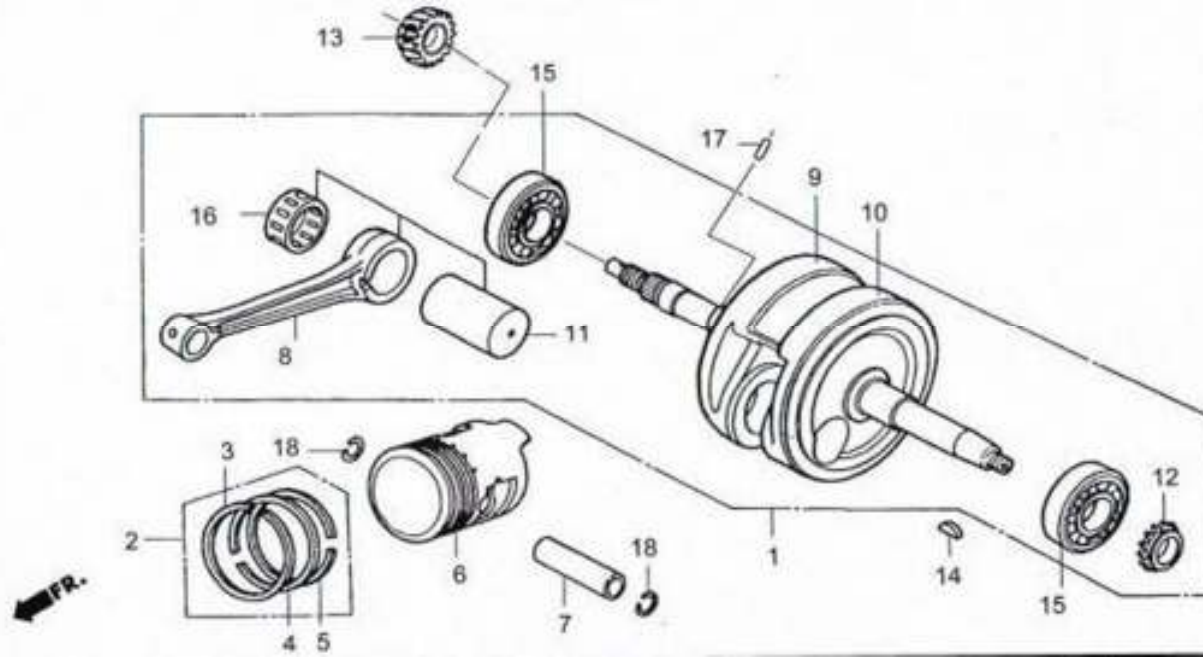

No.	VMEP CODE	(RM) SELLING PRICE	Description	No.	Remark
9	13310-VA1-3002(X)		R. Crank Shaft Comp.	1	please order parent part,E15-1,13000-VA1-0002
10	13321-VA1-3003(X)		L. Crank Shaft	1	please order parent part,E15-1,13000-VA1-0002
11	13381-VA2-3001	19.60	Crank Pin	1	
12	14311-VA2-3000	16.30	Timing Sprocket (16T)	1	
13	15341-VA2-0001	19.60	Oil Pump Driver Gear	1	
14	90741-M8Q-0000	2.60	Key Woodruff 4 mm	1	
15	91001-M36-0001	26.20	Radial Ball Brearing 6304 (TMB)	2	
16	91002-VA2-0000	18.70	Con-Rod Big End Bearing	1	
17	94303-03050	0.80	Dowel Pin 3x5	1	
18	94601-13000-00	0.40	Piston Pin Clip 13 mm	2	

PRICE SHOWN IS PER PIECE. PRODUCT IMAGE PRICES ARE APPROXIMATE GUIDE ONLY.
PRICES SHOWN ARE SUBJECT TO CHANGE WITHOUT PRIOR NOTICE.

E-16

BỘ SỐ TRANSMISSION

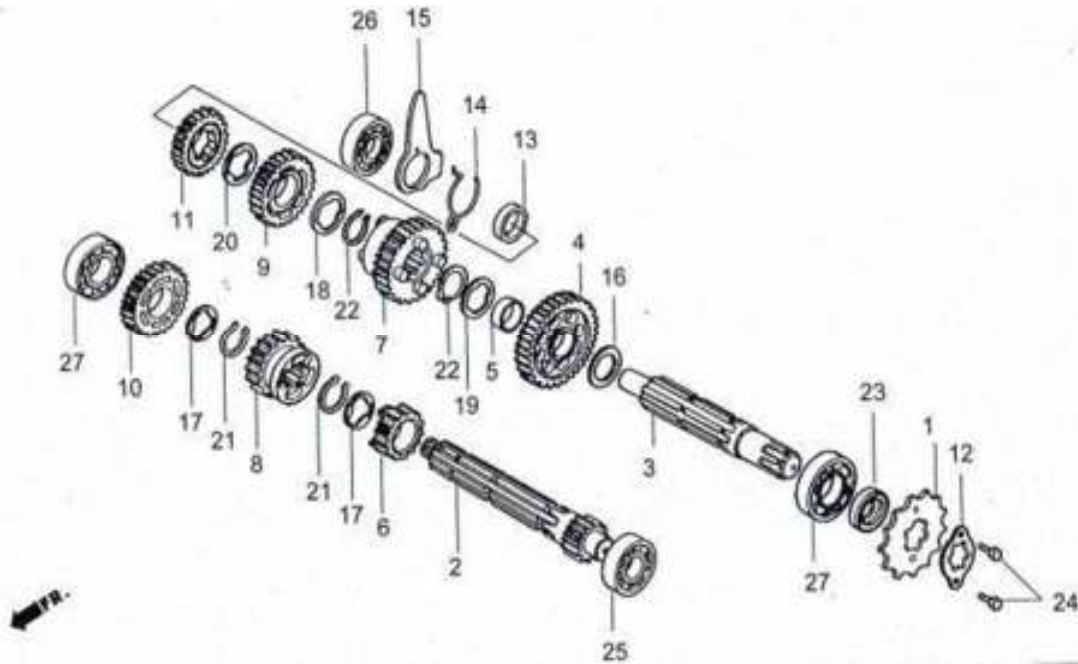

STT No.	VMEP CODE	(RM) SELLING PRICE	Description	No.	Ghi chú Remark
1	22711-SB1-0000	7.50	Drive Sprocket (14T)	1	
2	23211-VA2-0000	63.60	Main Shaft (12T)	1	
3	23221-VA2-0001	33.70	Counter Shaft	1	
4	23421-VA2-0001	37.10	C-1 Gear (34T)	1	
5	23422-VA2-0000	3.70	Bush 20x9	1	
6	23431-VA2-0000	33.00	M-2 Gear (17T)	1	
7	23441-VA2-0001	33.70	C-2 Gear (29T)	1	
8	23451-VA2-0000	37.50	M-3 Gear (21T)	1	
9	23461-VA2-0000	41.20	C-3 Gear (26T)	1	
10	23471-VA2-0000	41.20	M-4 Gear (24T)	1	
11	23481-VA2-0001	41.20	C-4 Gear (23T)	1	
12	23802-M36-0000	1.20	Drive Sprocket Fixing Plate	1	
13	23911-VA2-0000	0.80	Collar	1	
14	24305-VA2-0001	1.70	Gear Shift Drum Lock Spring	1	
15	24306-VA2-0000	4.10	Gear Shift Drum Lock Plate	1	
16	90452-VA2-0000	0.70	Thrust Washer 17 mm	1	

PRICE SHOWN IS PER PIECE. PRODUCT IMAGE PRICES ARE APPROXIMATE GUIDE ONLY.
PRICES SHOWN ARE SUBJECT TO CHANGE WITHOUT PRIOR NOTICE.

E-16

BỘ SỐ TRANSMISSION

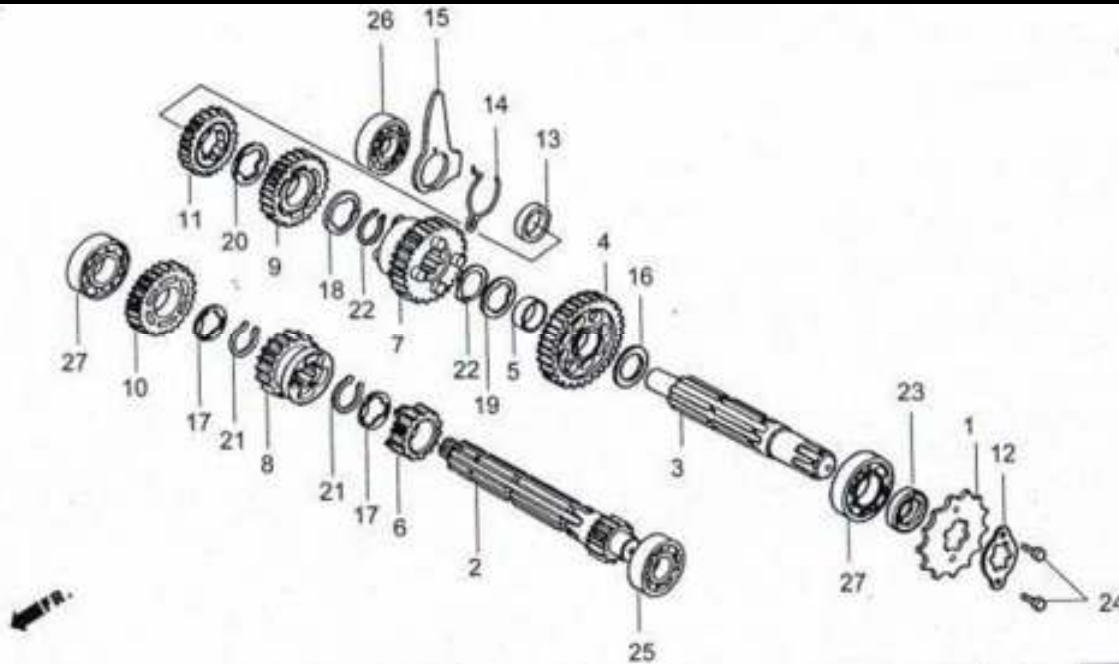

No.	VMEP CODE	(RM) SELLING PRICE	Description	No.	Remark
17	90461-VA2-0001-M1	0.70	Spline Washer 17 mm	2	
18	90462-VA2-0000	1.10	Spline Washer 20 mm	1	
19	90463-VA2-0000	1.80	Spline Washer 20x1.2	1	
20	90462-VA2-0000	1.10	Spline Washer 20 mm	1	
21	90601-A08-0001	1.10	Ex. Cir-Clip 17 mm	2	
22	90605-A08-0002	1.60	Set Ring 20 mm	2	
23	91203-VA2-0000	2.20	Oil Seal 17x29x5	1	
24	92101-06010-OH	0.40	Hex Bolt 6x10	2	Change from 92101-06010-0A
25	96140-60010-00	8.00	Radial Ball Bearing 6001 (CJB)	1	
26	90912-M9Q-0000-M1	8.20	Radial Ball Bearing 6201 (CJB)	1	
27	96100-62030-00	9.70	Radial Ball Bearing 6203 (CJB)	2	

PRICE SHOWN IS PER PIECE. PRODUCT IMAGE PRICES ARE APPROXIMATE GUIDE ONLY.
PRICES SHOWN ARE SUBJECT TO CHANGE WITHOUT PRIOR NOTICE.

E-17

TRỐNG SỐ

GEAR SHIFT DRUM

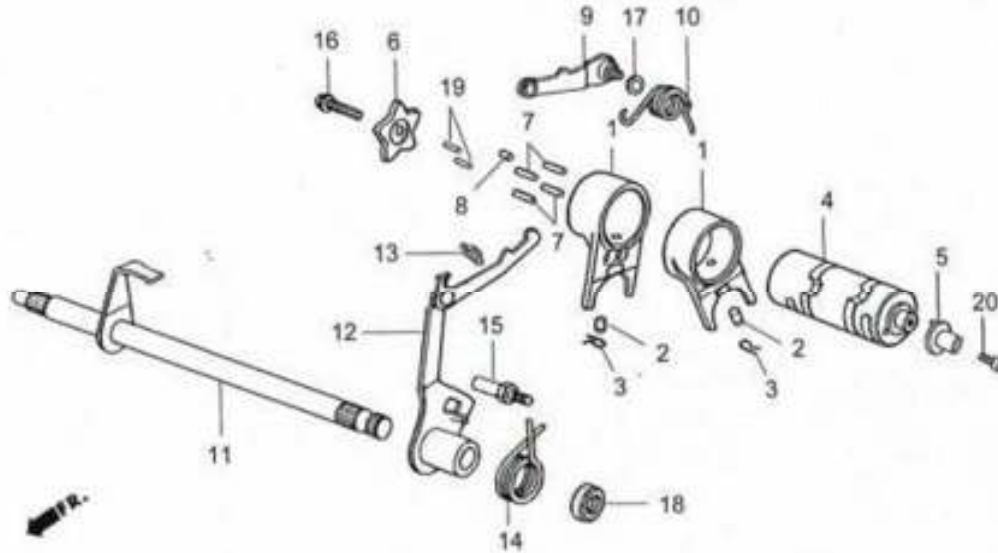

No.	VMEP CODE	(RM) SELLING PRICE	Description	No.	Remark
1	24211-VA2-0001	37.10	Gear Shift Fork	2	PARENT PART 2430A-VA2-0004
2	24261-VA2-0000	2.10	Gear Shift Fork Guide Pin	2	PARENT PART 2430A-VA2-0004
3	24263-M8Q-0000	1.20	Gear Shift Fork Guide Pin Clip	2	PARENT PART 2430A-VA2-0004
4	24301-VA2-0002	56.20	Gear Shift Drum	1	PARENT PART 2430A-VA2-0004
5	24320-VA2-0000	3.20	Contact Drive Plate Comp.	1	
6	24411-VA2-0001	2.10	Gear Shift Cam	1	PARENT PART 2430A-VA2-0004
7	24421-VA2-0000	1.20	Gear Shift Drum Pin	4	PARENT PART 2430A-VA2-0004
8	24422-VA2-0000	1.20	Gear Shift Drum Pin 8.7 mm	1	PARENT PART 2430A-VA2-0004
9	24430-VA2-0002	4.10	Shift Drum Stopper Comp.	1	
10	24435-VA2-0001	1.20	Gear Shift Drum Stopper Spring	1	
11	24610-VA2-3002	37.50	Gear Shift Spindle Comp.	1	
12	24630-VA2-0003	28.10	Gear Shift Arm Comp.	1	(PARENT PART)
	24633-M8Q-3000(X)		Gear Shift Arm Pivot Colar	1	please order parent part,E17-12,24630-VA2-0003
	24634-VA2-0001(X)		Gear Shift Arm	1	please order parent part,E17-12,24630-VA2-0003
	24635-VA2-3000(X)		Gear Shift Arm Master	1	please order parent part,E17-12,24630-VA2-0003
	24636-M8Q-3000(X)		Gear Shift Arm Pivot Pin	1	please order parent part,E17-12,24630-VA2-0003
13	24641-M8Q-0000(X)		Gear Shift Arm Spring	1	please order parent part,E17-12,24630-VA2-0003

PRICE SHOWN IS PER PIECE. PRODUCT IMAGE PRICES ARE APPROXIMATE GUIDE ONLY.
PRICES SHOWN ARE SUBJECT TO CHANGE WITHOUT PRIOR NOTICE.

E-17

TRỐNG SỐ

GEAR SHIFT DRUM

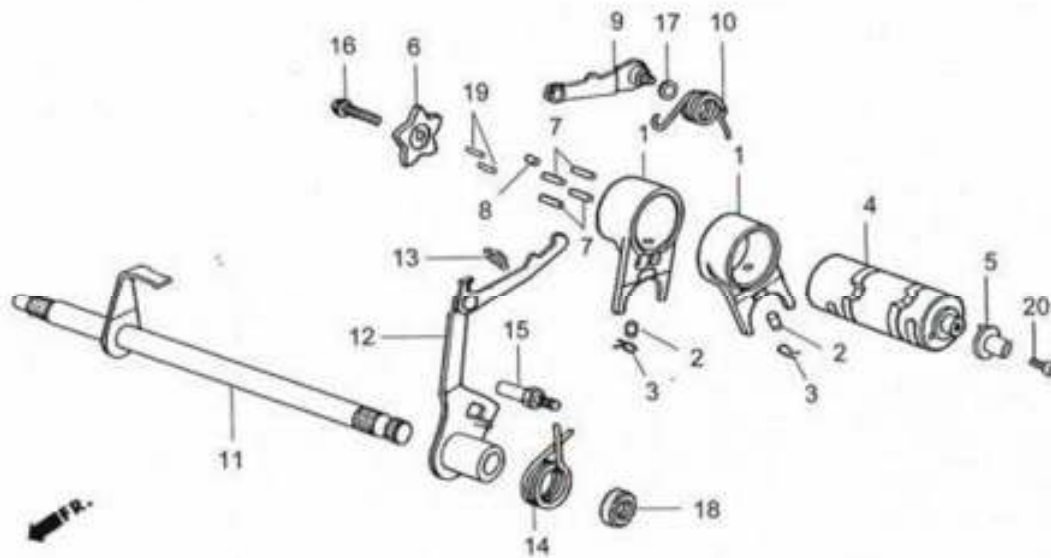

No.	VMEP CODE	SELLING PRICE	Description	No.	Remark
14	24651-M8Q-0000	2.40	Gear Shift Return Spring	1	
15	24652-M36-0000	4.00	Shift Arm Stopper Pin	1	
16	90071-M8Q-0000	0.70	Knock Bolt 6 mm	1	PARENT PART 2430A-VA2-0004
17	90479-X01-0000	0.70	Washer 6 mm	1	
18	91208-VA2-0000	2.20	Oil Seal 11.6x24x10	1	
19	96220-30085	0.70	Roller 3x8.5	2	PARENT PART 2430A-VA2-0004
20	96700-06016-00	0.70	Socket Bolt 6x16	1	

PRICE SHOWN IS PER PIECE. PRODUCT IMAGE PRICES ARE APPROXIMATE GUIDE ONLY.
 PRICES SHOWN ARE SUBJECT TO CHANGE WITHOUT PRIOR NOTICE.

E-18

TRỤC KHỞI ĐỘNG KICK STARTER SPINDLE

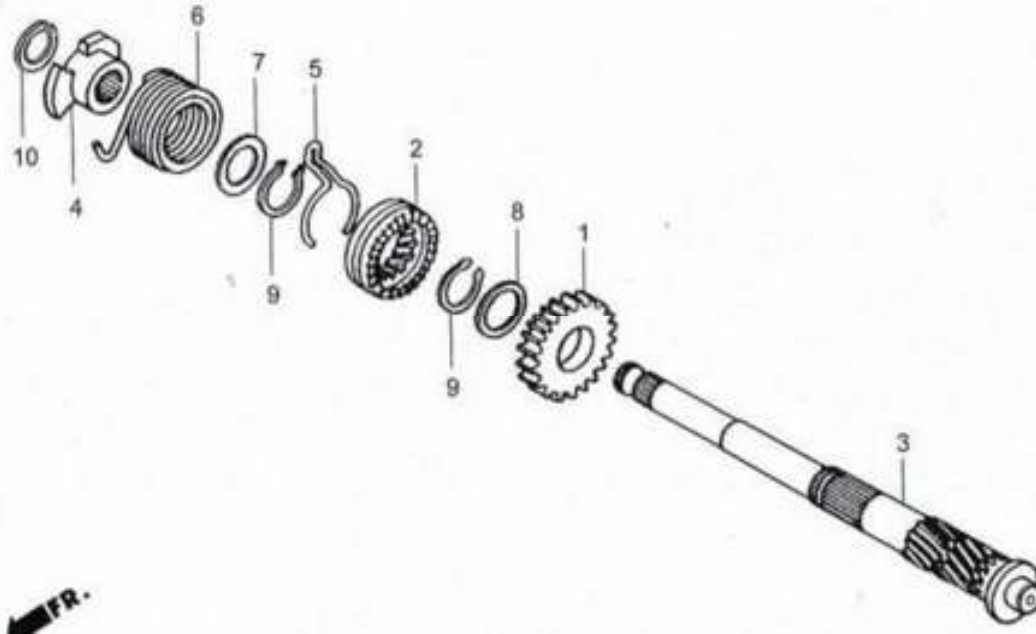

No.	VMEP CODE	(RM) SELLING PRICE	Description	No.	Remark
1	28211-178-0000	16.40	Kick Starter Pinion (22T)	1	
2	28221-A13-0000	12.30	Starter Drive Ratchet	1	
3	28251-VA2-0000	37.10	Kick Starter Spindle	1	
4	28262-A01-A000	3.00	Kick Spring Retainer	1	
5	28271-121-6900	3.00	Starter Pinion Friction Spring	1	
6	28281-035-0180	3.70	Kick Starter Spring	1	
7	90452-VA2-0000	0.70	Washer 17 mm	1	
8	90454-B04-0002	0.40	Thruster Washer 20 mm	1	
9	90605-A08-0002	1.60	Set Ring 20 mm	2	
10	94510-16000-00	2.10	Cir-Clip 16 mm	1	

PRICE SHOWN IS PER PIECE. PRODUCT IMAGE PRICES ARE APPROXIMATE GUIDE ONLY.
PRICES SHOWN ARE SUBJECT TO CHANGE WITHOUT PRIOR NOTICE.

E-19

BỘ CHẾ HÒA KHÍ CARBURETOR

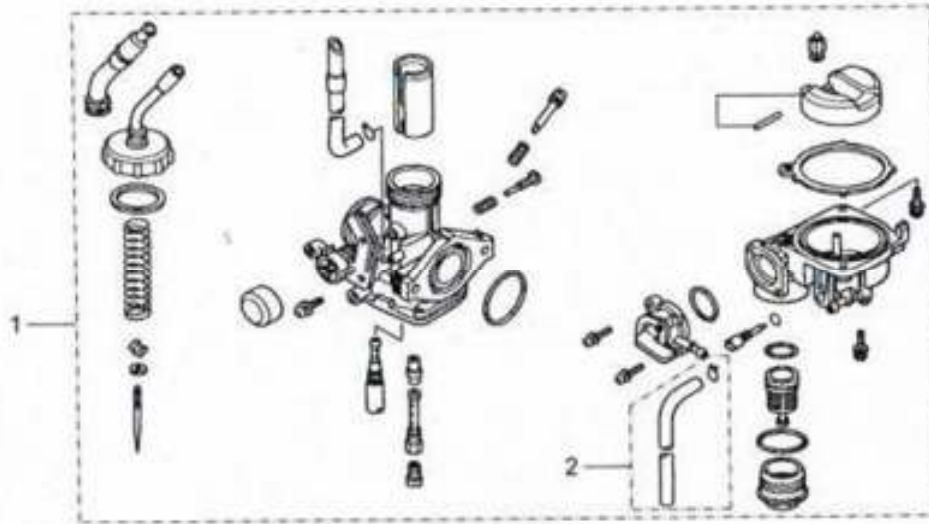

STT No.	VMEP CODE	(RM) SELLING PRICE	Description	STT No.	Ghi chú Remark
1	16100-A04-A003-VN	229.20	Carburetor Ass'y	1	
2	16101-VA6-0000	1.30	Rubber Tube Ass'y	1	

PRICE SHOWN IS PER PIECE. PRODUCT IMAGE PRICES ARE APPROXIMATE GUIDE ONLY.
PRICES SHOWN ARE SUBJECT TO CHANGE WITHOUT PRIOR NOTICE.

F-01

ĐÈN TRƯỚC
HEAD LIGHT

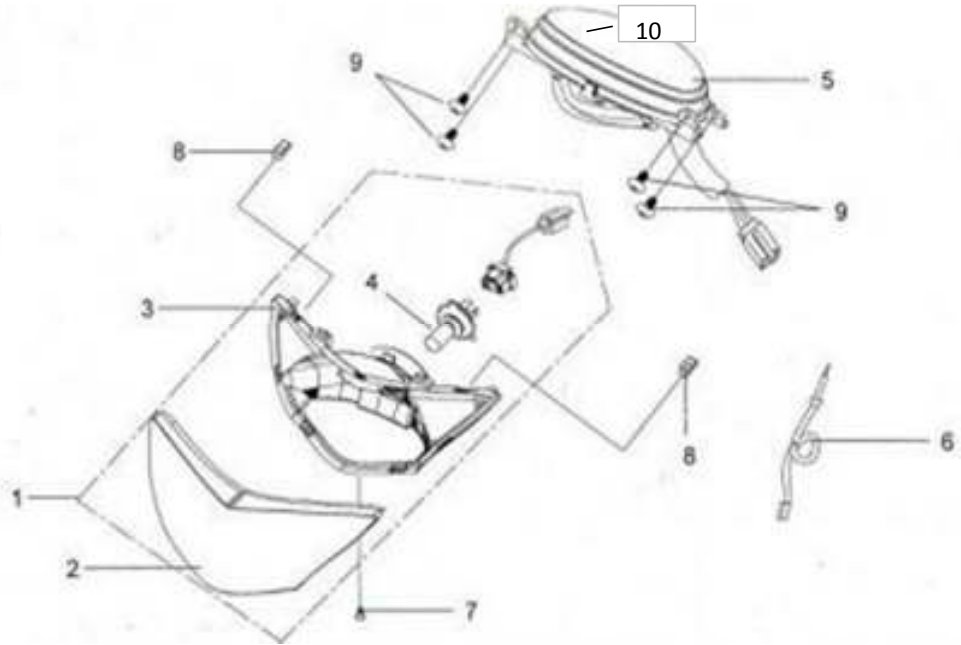

No.	VMEP CODE	(RM) Selling Price	Description	Unit	Remark
1	33100-SAF-0001	63.60	Head Light Ass'y	1	
2	33102-SAF-0000	16.80	Head Light Lens	1	
3	33106-SAF-0000	40.90	Head Light Base	1	
4	34901-SA5-0000	13.00	Head Light Bulb	1	
5	37200-SAH-0000	104.80	Speedometer Ass'y	1	
6	44830-SA5-0000	8.20	Speedometer Cable Comp.	1	
7	90101-VD3-0001	0.70	Adjust Bolt	1	
8	90651-T36-0000	0.70	Head Light Clip	2	
9	93903-35220-00	0.60	Tapping Screw 5x12	4	
10	37211-SAF-0000	14.70	Meter Lens	1	

PRICE SHOWN IS PER PIECE. PRODUCT IMAGE PRICES ARE APPROXIMATE GUIDE ONLY.
PRICES SHOWN ARE SUBJECT TO CHANGE WITHOUT PRIOR NOTICE.

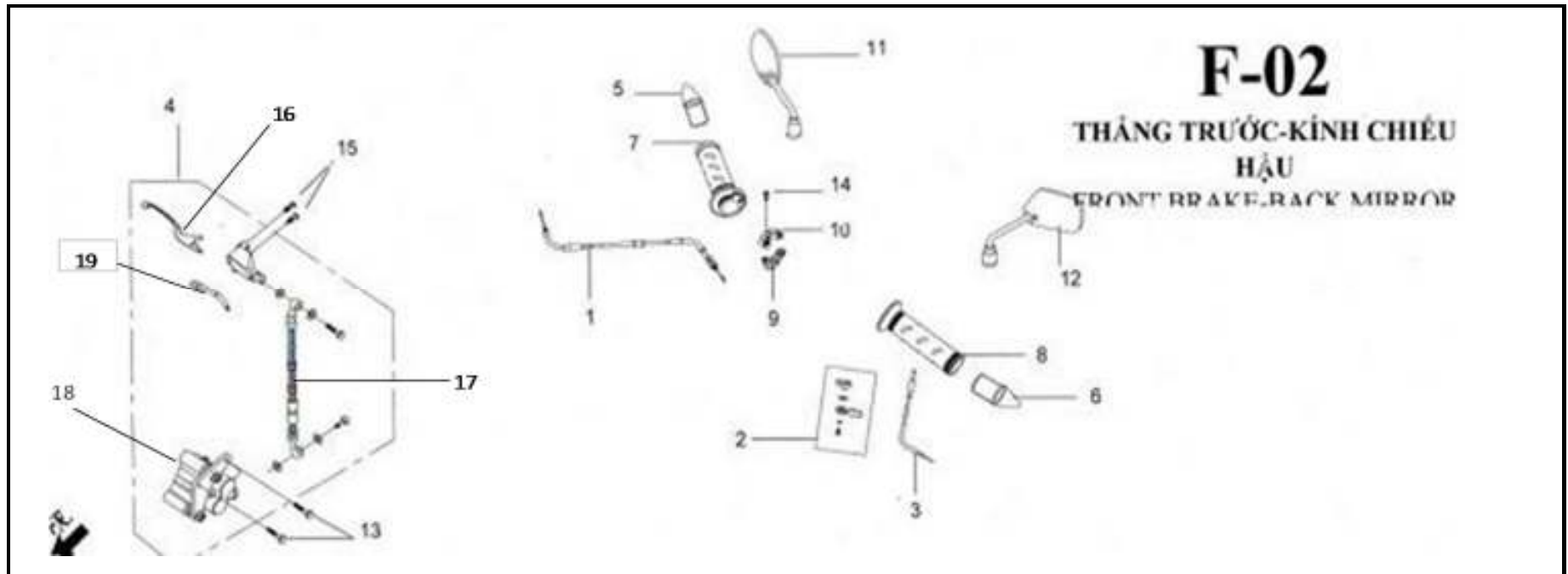

No.	VMEP CODE	(RM) Selling Price	Description	Unit	Remark	
1	17910-SAH-0000	6.00	Throttle Cable Comp.	1		
2	1795A-VAH-0000	5.60	Chock Lever comp	1		
3	17950-VAH-A000	5.60	Choke Cable Comp.	1		
4	4550A-SAB-0000	453.90	Fr. Brake Ass'y	1		
5	53102-VAE-0000		R. Handle Pipe WT Ass'y	1	PARENT PART, please order full set chil part	
	53105-VAE-0000	5.20	R. Handle . Pipe WT.	1	CHILD PART of 53102-VAE-0000	
	53104-M3B-0000	0.70	Handle WT. Rubber	1	CHILD PART of 53102-VAE-0000	N
	53108-N02-0001	1.00	Special Nut 6mm	1	CHILD PART of 53102-VAE-0000	N
	93700-06065-0G	1.00	Oval Screw 6X65	1	CHILD PART of 53102-VAE-0000	N
6	53103-VAE-0000		L. Handle Pipe WT Ass'y	1	PARENT PART, please order full set chil part	
	53106-M9P-0000	5.20	R. Handle . Pipe WT.	1	CHILD PART of 53103-VAE-0000	
	53104-M3B-0000	0.70	Handle WT. Rubber	1	CHILD PART of 53103-VAE-0000	N
	53108-N02-0001	1.00	Special Nut 6mm	1	CHILD PART of 53103-VAE-0000	N
	93700-06060-0G	0.90	Oval Screw 6X60	1	CHILD PART of 53103-VAE-0000	N

PRICE SHOWN IS PER PIECE. PRODUCT IMAGE PRICES ARE APPROXIMATE GUIDE ONLY.
 PRICES SHOWN ARE SUBJECT TO CHANGE WITHOUT PRIOR NOTICE.

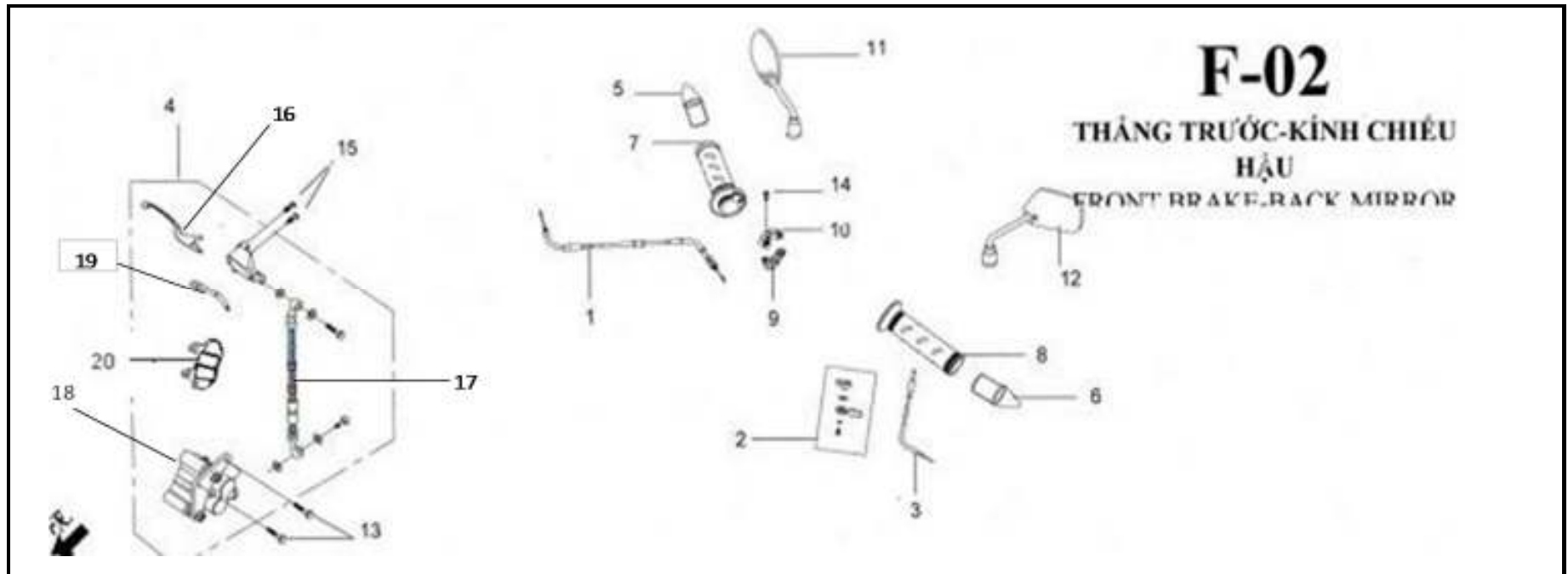

No.	VMEP CODE	(RM) Selling Price	Description	Unit	Remark
7	53140-VAH-0000	4.50	R. Handle Grip	1	
8	53166-VAH-0000	3.70	L. Handle Grip	1	
9	53167-H09-0001	3.70	Throttle Under Housing	1	
10	53168-H09-0001	3.70	Throttle Upper Housing	1	
11	88110-SA5-9000	10.90	R. Back Mirror Ass'y	1	
12	88120-SA5-9000	10.90	L. Back Mirror Ass'y	1	
13	90122-VA1-0000	2.00	Flange Bolt 8x28	2	
14	93500-05022-00	0.40	Pan Screw 5x22	1	
15	96700-06012-08-L1	0.70	Socket Bolt 6x12	2	
16	53175-VN3-000	12.40	R. Steering Handle Lever	1	
17	45126-SAB-0000	45.80	Fr. Brk. Hose Ass'y	1	
18	45100-SAB-0001	175.20	Fr. Caliper Ass'y	1	
19	10099-986-1500	16.30	Fr. Stop Switch Ass'y	1	
20	45105-VA1-0000	47.70	Pad comp A+B	1	

PRICE SHOWN IS PER PIECE. PRODUCT IMAGE PRICES ARE APPROXIMATE GUIDE ONLY.
 PRICES SHOWN ARE SUBJECT TO CHANGE WITHOUT PRIOR NOTICE.

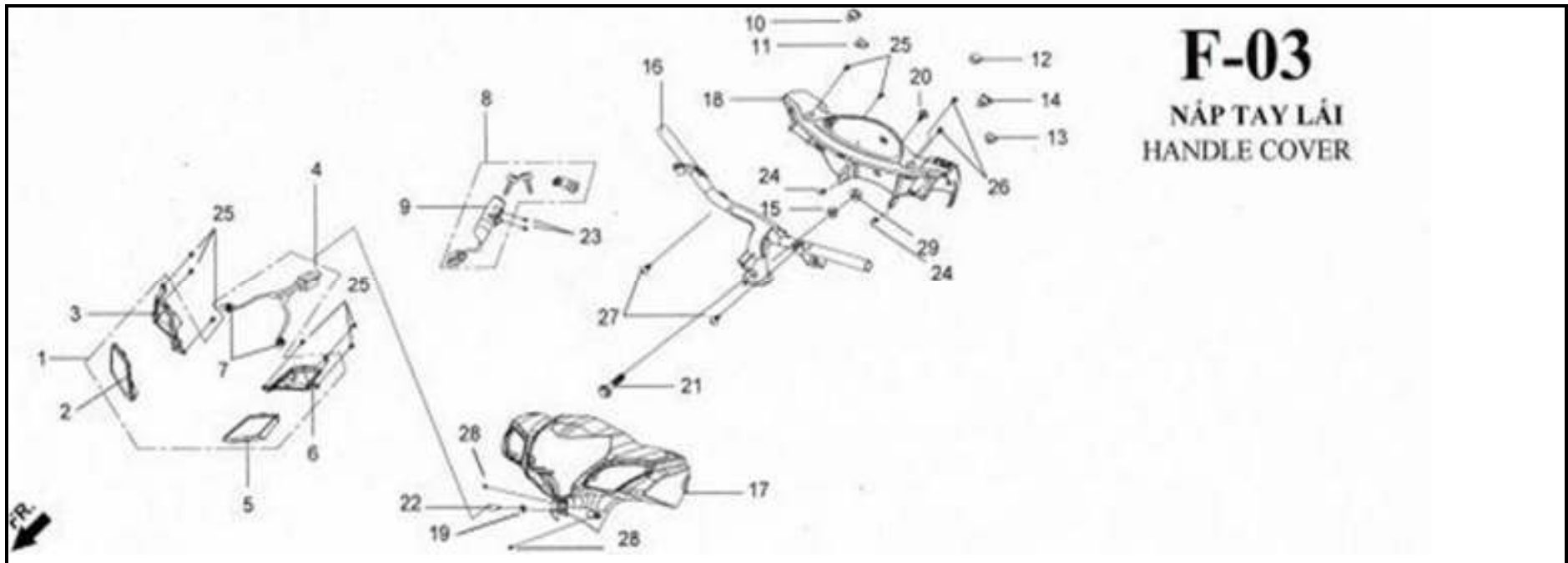

F-03

NÁP TAY LÁI
HANDLE COVER

No.	VMEP CODE	(RM) Selling Price	Description	Unit	Remark
1	3340A-VD3-0002	27.70	Fr. Winker Light Ass'y	1	
2	33402-VD3-0000	5.20	R. Fr. Winker Lens	1	
3	33411-VD3-0001	6.50	R. Fr. Winker Base	1	
4	33406-VD3-0000	5.10	Fr. Winker Socket Comp.	1	
5	33462-VD3-0000	5.20	L. Fr. Winker Lens	1	
6	33461-VD3-0001	6.50	L. Fr. Winker Base	1	
7	34905-M9Q-0000	2.90	Winker Light Bulb	2	
8	35010-SA5-0000	56.20	Key Set	1	(PARENT PART)
9	35100-SA5-0000		Comp. & Switch Lock Ass'y	1	CHILD PART of 35010-SA5-0000
10	35150-SAF-0000	7.50	Lighting Switch Unit	1	
11	35160-SAF-0000	9.30	Start Switch Unit	1	
12	35170-SAF-0000	9.30	Dimmer Switch Unit	1	
13	35180-SAF-0000	7.50	Horn Switch Unit	1	
14	35200-M9Q-0001	8.20	Winker Switch Unit	1	
15	47104-SB1-0000	1.30	Handle Set Collar	1	
16	53100-SAH-0001	44.40	Handle Pipe Comp.	1	

PRICE SHOWN IS PER PIECE. PRODUCT IMAGE PRICES ARE APPROXIMATE GUIDE ONLY.
PRICES SHOWN ARE SUBJECT TO CHANGE WITHOUT PRIOR NOTICE.

F-03

NÁP TAY LÁI

HANDLE COVER

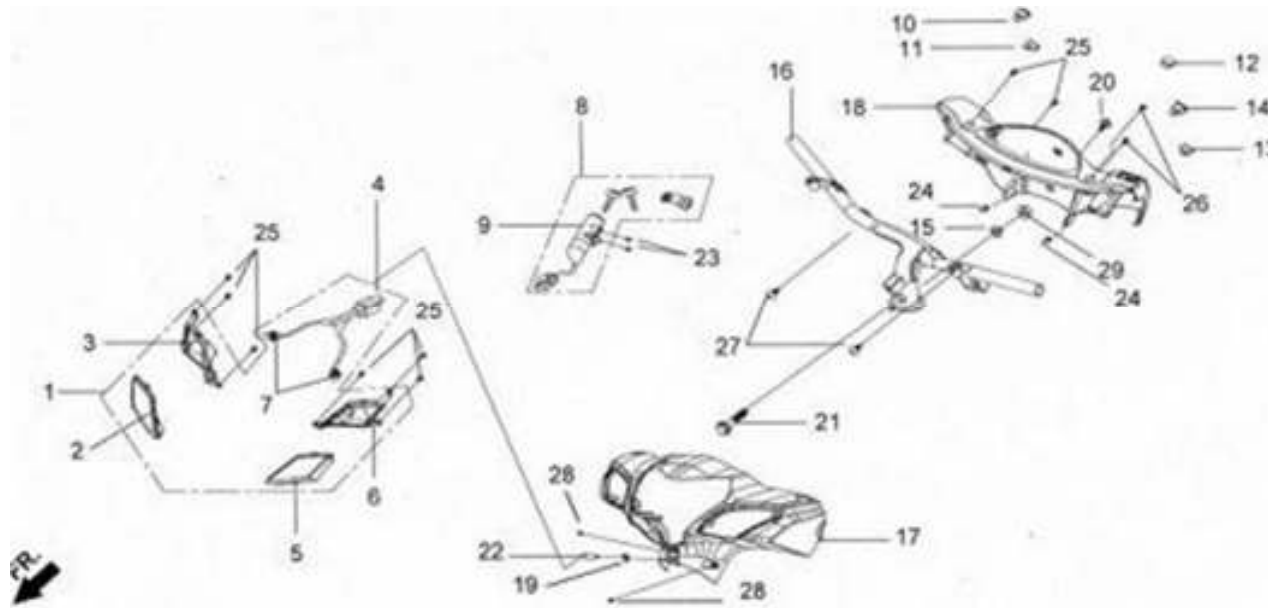

No.	VMEP CODE	(RM) Selling Price	Description	Unit	Remark
17	53205-SAF-0003-KB	22.60	Fr. Handle Cover (black)	1	
	53205-SAF-0003-RE	22.60	Fr. Handle Cover (red)	1	
	53205-SAF-0003-DH	22.60	Fr. Handle Cover (blue)	1	
	53205-SAF-0003-WF	22.60	Fr. Handle Cover (white)	1	
	53205-SAF-0003-YL	22.60	Fr. Handle Cover (Orange)	1	
18	53206-SAF-0001	14.50	Rr. Handle Cover	1	
19	90104-VA1-0000	0.70	Fr. Fork Cover Collar	1	
20	90105-M40-0000	0.40	Special Screw 5x12	1	
21	90106-TAA-0001	1.60	Flange Bolt 10x50	1	
22	90115-VA3-0000	1.10	Body Cover Bolt 6x18	1	
23	90164-X01-0002	0.70	Flat Lock Screw 6x12	2	
24	90302-SA4-003B	0.70	Spring Nut 4mm	2	
25	93903-24220-10	0.60	Tapping Screw 4x10	6	
26	93903-34480-00	0.60	Tapping Screw 4x16	4	
27	93903-35180-00	0.60	Tapping Screw 5x10	2	
28	93903-44480	0.60	Tapping Screw 4x16	2	
29	94050-10080-00	0.70	Flange Nut 10 mm	1	

PRICE SHOWN IS PER PIECE. PRODUCT IMAGE PRICES ARE APPROXIMATE GUIDE ONLY.
 PRICES SHOWN ARE SUBJECT TO CHANGE WITHOUT PRIOR NOTICE.

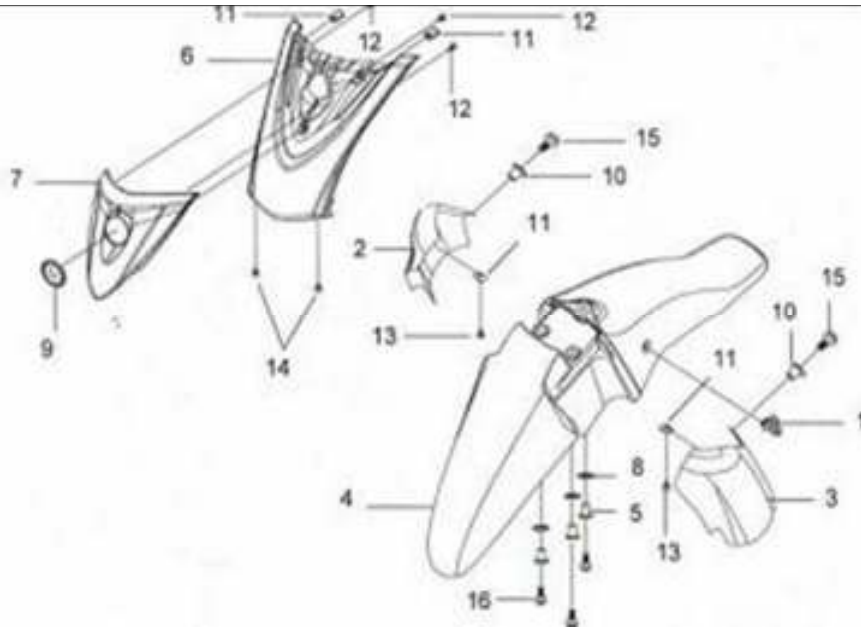

F-04

MẶT NẠ TRƯỚC-VÈ TRƯỚC TOP COVER-FRONT FENDER

No.	VMEP CODE	(RM) Selling Price	Description	Unit	Remark
1	45451-N02-0000	1.50	Wire Grommet	1	
2	51103-VA1-0002-KB	11.30	R. Front Fork Cover(black)	1	
	51103-VA1-0002-RB	11.30	R. Front Fork Cover (red)	1	
	51103-VA1-0002-DH	11.30	R. Front Fork Cover (blue)	1	
	51103-VA1-0002-WF	11.30	R. Front Fork Cover (white)	1	
	51103-VA1-0002-YL	11.30	R. Front Fork Cover (orange)	1	
3	51104-VA1-0002-KB	11.30	L. Front Fork Cover (black)	1	
	51104-VA1-0002-RB	11.30	L. Front Fork Cover (red)	1	
	51104-VA1-0002-DH	11.30	L. Front Fork Cover (blue)	1	
	51104-VA1-0002-WF	11.30	L. Front Fork Cover (white)	1	
	51104-VA1-0002-YL	11.30	L. Front Fork Cover (orange)	1	
4	61200-VA1-0003-KB	32.30	Fr. Fender(black)	1	
	61200-VA1-0003-RB	32.30	Fr. Fender (red)	1	
	61200-VA1-0003-DH	32.30	Fr. Fender (blue)	1	
	61200-VA1-0003-WF	32.30	Fr. Fender (white)	1	
	61200-VA1-0003-YL	32.30	Fr. Fender (orange)	1	
5	61201-M3G-0000-A	0.70	Fr. Fender Collar	3	

PRICE SHOWN IS PER PIECE. PRODUCT IMAGE PRICES ARE APPROXIMATE GUIDE ONLY.
PRICES SHOWN ARE SUBJECT TO CHANGE WITHOUT PRIOR NOTICE.

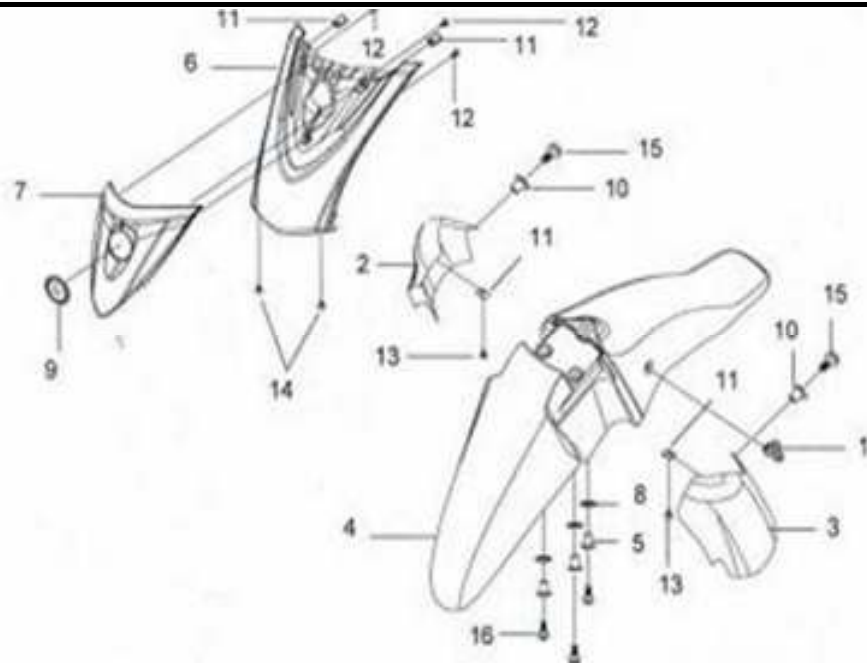

F-04

MẶT NẠ TRƯỚC-VÈ TRƯỚC
TOP COVER-FRONT FENDER

No.	VMEP CODE	(RM) Selling Price	Description	Unit	Remark
6	64310-SA5-0005-RB	15.00	Fr. Top Cover (red- 010CA)	1	
	64310-SA5-0005-SV	15.00	Fr. Top cover (silver-420)	1	
7	64312-SA5-0000-IF	16.80	Fr. Top Cover Emblem	1	
8	77226-M3F-0000	0.40	Damping Rubber	3	
9	87123-H85-0000	7.50	S Logo (40 Poly)	1	
10	90104-VA1-0000	0.70	Fr. Fork Cover Collar	2	
11	90302-SA4-003B	0.70	Spring Nut 4 mm	4	
12	93903-34320-00	0.60	Tapping Screw 4x12	3	
13	93903-44320-00	0.60	Tapping Screw 4x12	2	
14	93903-44480	0.60	Tapping Screw 4x16	2	
15	95801-06014-00	0.70	Flange Bolt 6x14	2	
16	95801-06020-00	0.70	Flange Bolt 6x20	3	

PRICE SHOWN IS PER PIECE. PRODUCT IMAGE PRICES ARE APPROXIMATE GUIDE ONLY.
PRICES SHOWN ARE SUBJECT TO CHANGE WITHOUT PRIOR NOTICE.

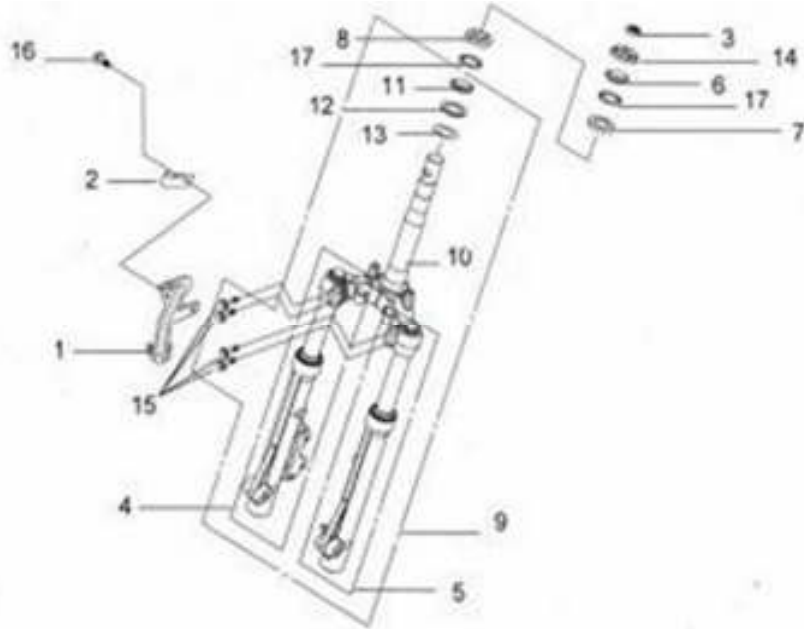

F-05

BỘ PHỤ CỤ TRƯỚC FRONT FORK SET

No.	VMEP CODE	(RM) Selling Price	Description	Unit	Remark
1	45156-VA1-0002	2.90	Brake Hose Clamp	1	
2	45157-VA1-0001	2.90	Brake Hose Clamp B	1	
3	51718-SB1-0000	5.70	Steering Stem Lock Nut	1	
4	51400-VAG-0000	121.10	R. Fr. Cushion Ass'y	1	chil part of 5320A-SAE-0000
5	51500-VAG-0000	121.10	L. Fr. Cushion Ass'y	1	chil part of 5320A-SAE-0000
4,5-1	51401-VD3-0000	8.30	SPRING	1	
4,5-2	51410-VD3-0000	60.50	FORK PIPE COMP	1	
4,5-3	51412-VD3-0000	2.80	REBOUND SPRING	1	
4,5-4	51421-VAG-0000	72.70	BOTTOM CASE - RH	1	
4,5-5	51432-X15-0000	3.80	OIL LOCK PIECE	1	
4,5-6	51437-X15-0000	1.00	PISTON RING	1	
4,5-7	51440-VD3-0000	8.70	PIPE SEAT	1	
4,5-8	51493-M36-0000	0.40	O-RING	1	
4,5-9	51521-VAG-0000	72.70	BOTTOM CASE - LH	1	
4,5-10	90103-VD3-0000	13.80	FORK BOLT	1	
4,5-11	90110-VD3-0000	2.80	DUST SEAL	1	
4,5-12	90116-383-7211-M1	1.00	SCOKET BOLT 8MM	1	

PRICE SHOWN IS PER PIECE. PRODUCT IMAGE PRICES ARE APPROXIMATE GUIDE ONLY.
PRICES SHOWN ARE SUBJECT TO CHANGE WITHOUT PRIOR NOTICE.

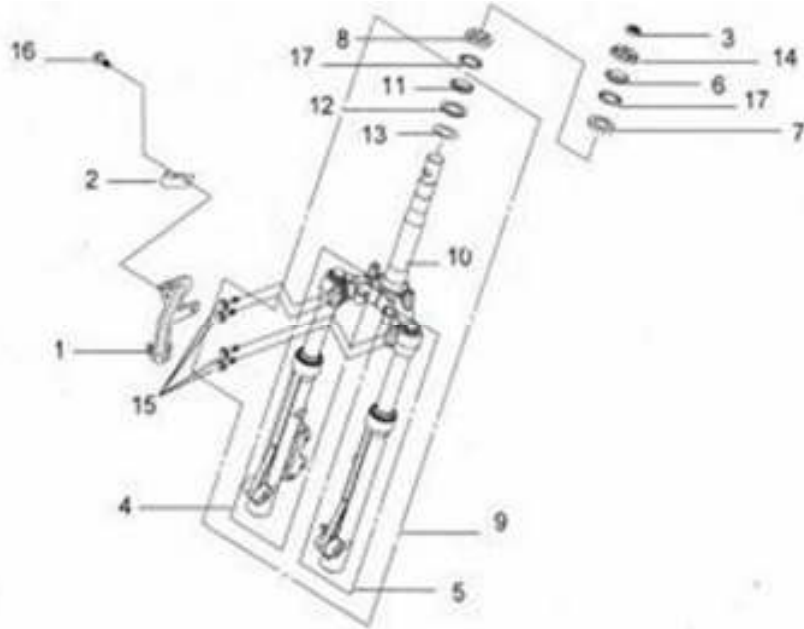

F-05

BỘ PHỤ CỤC TRƯỚC FRONT FORK SET

No.	VMEP CODE	(RM) Selling Price	Description	Unit	Remark
4,5-13	90544-S08-0000	2.60	PACKING 8MM	1	
4,5-14	90601-X15-0000	0.70	OIL SEAL STOPPER RING	1	
4,5-15	91255-VD3-0000	7.20	OIL SEAL	1	
6	51711-SB1-0000	5.70	Steering Top Cone Race	1	
7	51712-SB1-0000	5.70	Steering Top Ball Race	1	
8	51713-SB1-0000	5.70	Steering Bottom Ball Race	1	
9	5320A-SAE-0000(X)		Fr. Fork Set	1	(PARENT PART), please order full set chil part
10	53200-VX3-0000	131.00	Steering Stem Comp.	1	chil part of 5320A-SAE-0000
11	53212-VA3-0000	11.20	Steering Bottom Cone Race	1	chil part of 5320A-SAE-0000
12	53214-X04-0000	2.00	Steering Head Dust Seal	1	chil part of 5320A-SAE-0000
13	53215-X04-0001	0.70	Steering Head Dust Seal Washer	1	chil part of 5320A-SAE-0000
14	53220-VA3-0001	8.20	Steering Head Top Thread	1	
15	90105-VA1-0001	2.00	Flange Bolt 10x42.5	4	chil part of 5320A-SAE-0000
16	96001-06010-08	0.80	Sh. Flange Bolt 6x10	1	
17	9621A-06000-00	32.00	Steel Ball 6	50	RM 32 PER SET (100PCS)

PRICE SHOWN IS PER PIECE. PRODUCT IMAGE PRICES ARE APPROXIMATE GUIDE ONLY.
PRICES SHOWN ARE SUBJECT TO CHANGE WITHOUT PRIOR NOTICE.

F-06

BỤNG TRƯỚC-YẾM XE
FRONT COVER-MAIN PIPE UP
COVER

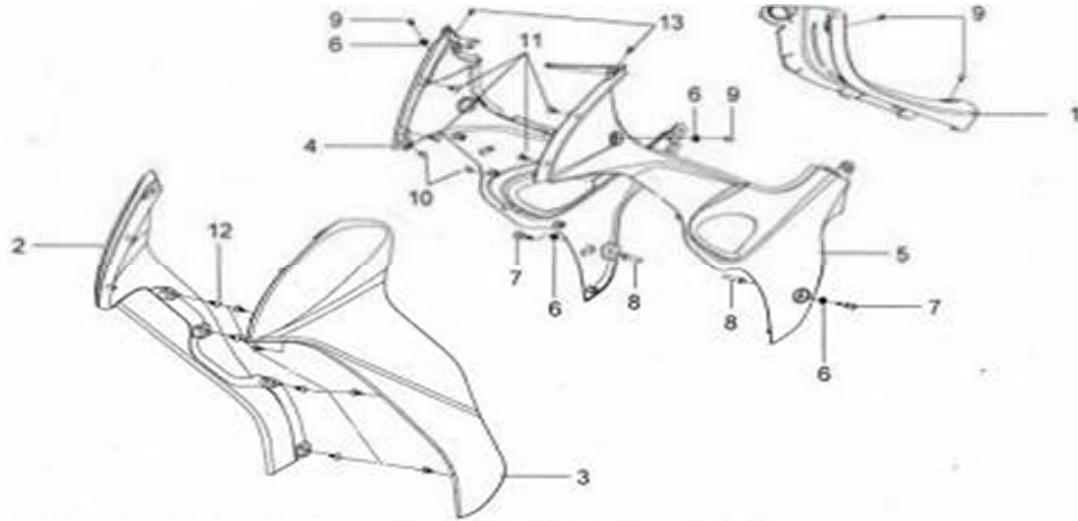

No.	VMEP CODE	(RM) Selling Price	Description	Unit	Remark
1	64100-SA5-0000	13.60	Main Pipe Up Cover	1	
2	64301-SA5-0003-KB	42.00	R. Front Cover (black)	1	
	64301-SA5-0003-RB	42.00	R. Front Cover (red)	1	
	64301-SA5-0003-DH	42.00	R. Front Cover (blue)	1	
	64301-SA5-0003-WF	42.00	R. Front Cover (white)	1	
	64301-SA5-0003-YL	42.00	R. Front Cover (yellow)	1	
3	64302-SA5-0003-KB	42.00	L. Front Cover (black)	1	
	64302-SA5-0003-RB	42.00	L. Front Cover (red)	1	
	64302-SA5-0003-DH	42.00	L. Front Cover (blue)	1	
	64302-SA5-0003-WF	42.00	L. Front Cover (white)	1	
	64302-SA5-0003-YL	42.00	L. Front Cover (yellow)	1	
4	64303-SA5-0002-RB	18.00	R. Main Pipe Cover (Red-010CA)	1	
	64303-SA5-0002-SV	18.00	R. Mian Pipe Cover (silver -420)	1	
5	64304-SA5-0002-RB	18.00	L. Main Pipe Cover(red-010CA)	1	
	64304-SA5-0002-SV	18.00	L. Main Pipe Cover (silver-420)	1	
6	64304-X01-0000	0.70	Fr. Cover Rubber	4	
7	64305-SA5-A000	1.10	Fr. Cover Screw	2	
8	64307-SA5-A000	1.10	Fr. Cover Collar	2	
9	90110-GZ0-000A	0.70	Special Screw 6x14	4	
10	90302-SA4-003B	0.70	Spring Nut 4 mm	2	
11	93903-34320-00	0.60	Tapping Screw 4x12	4	
12	93903-35220-00	0.60	Tapping Screw 5x12	8	
13	93903-44480	0.60	Tapping Screw 4x16	2	

PRICE SHOWN IS PER PIECE. PRODUCT IMAGE PRICES ARE APPROXIMATE GUIDE ONLY.
PRICES SHOWN ARE SUBJECT TO CHANGE WITHOUT PRIOR NOTICE.

F-07

BÁNH TRƯỚC-THẮNG ĐĨA FRONT WHEEL-BRAKE DISK

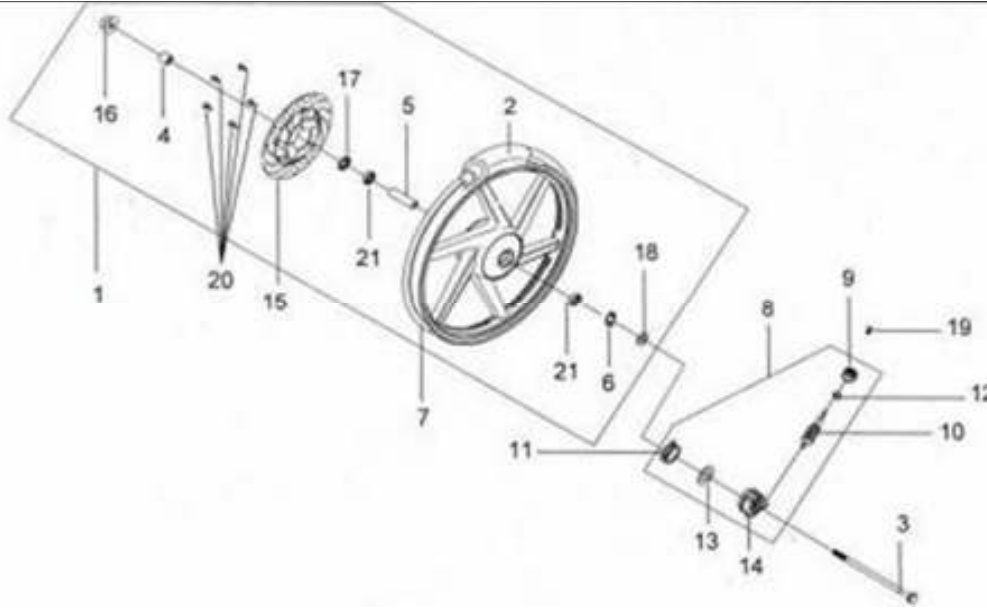

No.	VMEP CODE	(RM) Selling Price	Description	Unit	Remark
1	44600-SAH-000		Fr. Wheel Ass'y	1	
2	44710-VA2-000		Fr. Tire Ass'y	1	
3	44301-VA5-0001	7.50	Fr. Wheel Axle	1	
4	44311-M67-0000	3.00	Fr. Wheel Side Collar	1	
5	44620-VA1-0000	3.00	Fr. Axle Distance Collar	1	
6	44680-VA1-000	2.10	Gear Box Retainer	1	
7	44701-VD7-0000	187.20	Fr. Wheel Cast	1	
8	44800-VA1-0001	44.90	Gear Box Ass'y	1	(PARENT PART)
9	44803-VA1-0000-M1(X)		Pinion Bush	1	CHILD PART of 44800-VA1-0001
10	44805-VA1-0000-M1(X)		Speedometer Pinion	1	CHILD PART of 44800-VA1-0001
11	44806-VA1-0001-M1(X)		Speedometer Gear	1	CHILD PART of 44800-VA1-0001
12	44907-VA1-0000-M1(X)		Gear Box Pinion Washer	1	CHILD PART of 44800-VA1-0001
13	44809-VA1-0000-M1(X)		Speedometer Gear Washer	1	CHILD PART of 44800-VA1-0001
14	44820-VA1-0000-M1(X)		Speedometer Gear Box Comp.	1	CHILD PART of 44800-VA1-0001
15	45121-VA1-0000	121.10	Fr. Brake Disk	1	
16	54207-SB1-0000	1.60	Fr. Axle Nut	1	
17	91252-030-003A	1.60	Oil Seal 23x37x7	1	
18	91258-410-0131	2.20	Dust Seal 40x50x5	1	
19	93891-05022-07	0.70	Washer Screw 5x22	1	
20	95801-VD7-0000	0.80	Flange Bolt 6x22	5	
21	96140-63010-10	10.00	Radial Ball Bearing 6301 (UU)	2	

PRICE SHOWN IS PER PIECE. PRODUCT IMAGE PRICES ARE APPROXIMATE GUIDE ONLY.
PRICES SHOWN ARE SUBJECT TO CHANGE WITHOUT PRIOR NOTICE.

F-08

MÁ ĐÙM SAU

REAR BRAKE PANEL

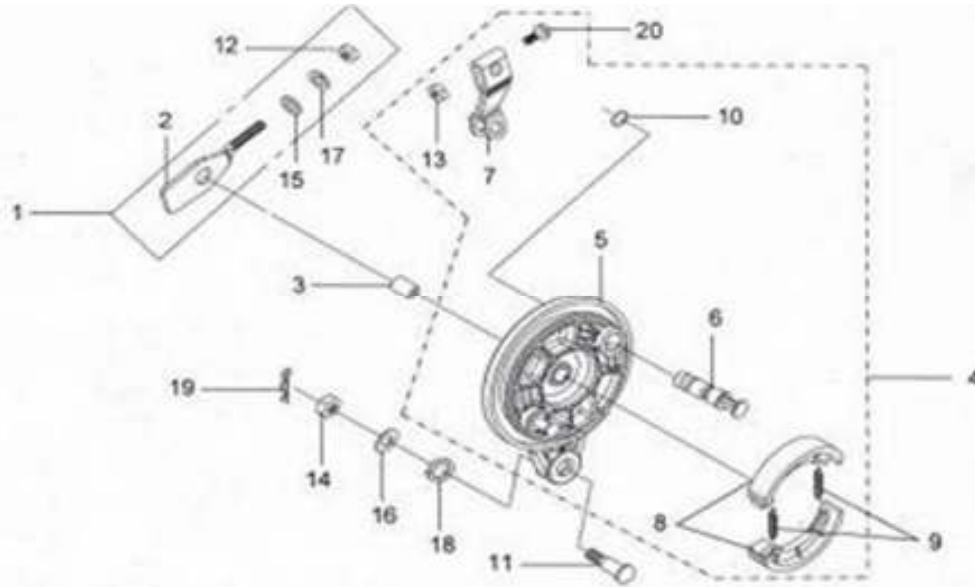

No.	VMEP CODE	(RM) Selling Price	Description	Unit	Remark
1	4054A-VAD-0000	4.90	R. Drive Chain Adjuster Ass'y	1	
2	40543-VAD-000		R. Drive Chain Adjuster	1	
3	42313-SAH-0000	3.50	Rr. Brake Panel Side Collar	1	
4	43000-VDA-0000(X)		Rr. Brake Panel Ass'y	1	PARENT PART, please order full set chil part
	43145-X01-0100	0.70	Rr. Brake Indicator	1	CHILD PART of 43000-VDA-0000
5	43100-X01-0202-SE	48.70	Rr. Brake Panel	1	CHILD PART of 43000-VDA-0000
6	43141-A02-0103	4.10	Brake Cam	1	CHILD PART of 43000-VDA-0000
7	43410-M3B-0001	6.50	Rr. Brake Arm	1	CHILD PART of 43000-VDA-0000
8	4512B-ADA-0000	13.70	Brake Shoe Comp.	2	CHILD PART of 43000-VDA-0000
9	45133-A10-0000	0.80	Brake Shoe Spring	2	CHILD PART of 43000-VDA-0000
10	45134-M9Q-0000	1.20	Brake Cam Dust Seal	1	
11	90127-M8Q-0000	0.70	Rr. Brake Torque Bolt	1	
12	94001-06000-00	0.60	Hex Nut 6 mm	1	
13	94050-06000-00	0.70	Flange Nut 6 mm	1	CHILD PART of 43000-VDA-0000
14	94050-08000	0.70	Flange Nut 8 mm	1	
15	94101-06000	0.40	Plain Washer 6 mm	1	
16	94101-08000	0.50	Plain Washer 8 mm	1	
17	94111-06000-00	0.40	Spring Washer 6 mm	1	
18	94111-10000-00	0.70	Spring Washer 10 mm	1	
19	94251-08400	0.80	Lock Pin 8 mm	1	
20	95701-06032-00	0.70	Flange Bolt 6x32 mm	1	CHILD PART of 43000-VDA-0000

PRICE SHOWN IS PER PIECE. PRODUCT IMAGE PRICES ARE APPROXIMATE GUIDE ONLY.
PRICES SHOWN ARE SUBJECT TO CHANGE WITHOUT PRIOR NOTICE.

F-09

BÁNH SAU
REAR WHEEL

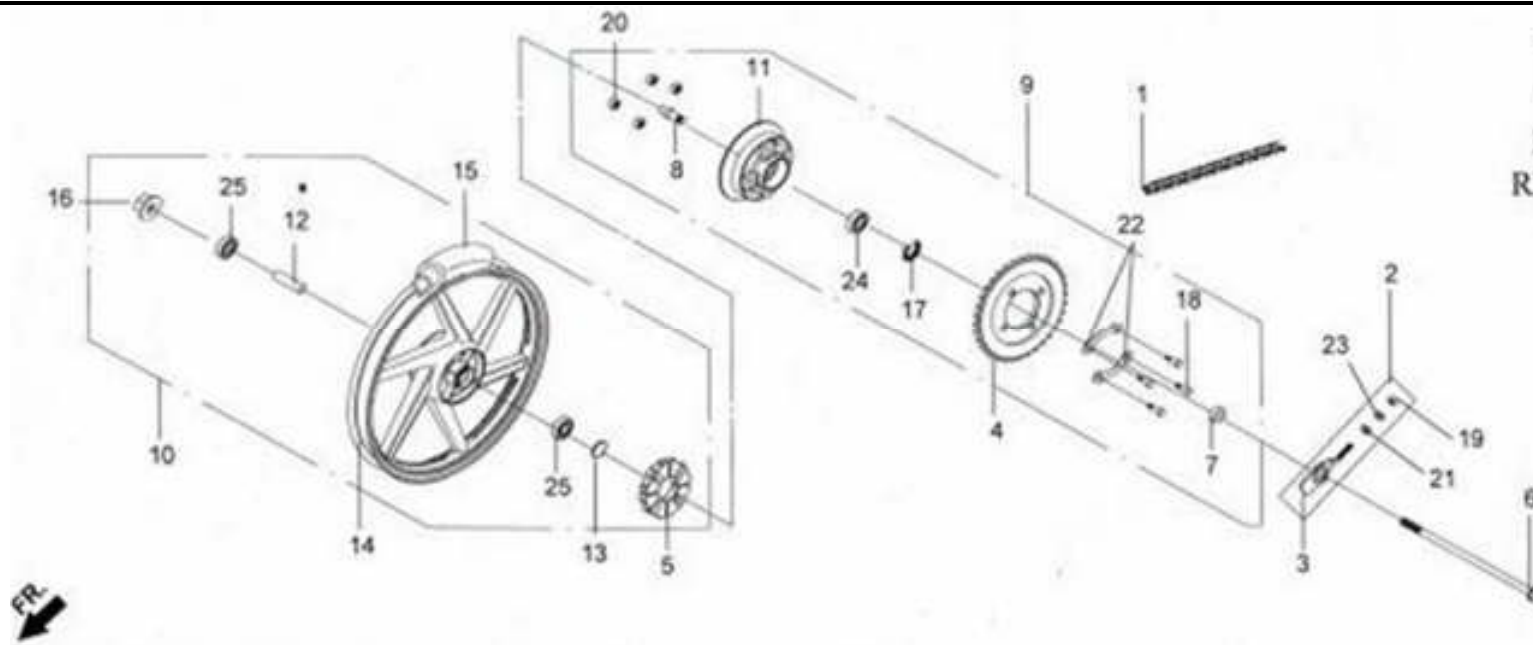

No.	VMEP CODE	(RM) Selling Price	Description	Unit	Remark
1	1CS 428H X 102L	23.20	Drive Chain (102L)	1	
2	4054A-VAD-0000	4.90	R. Drive Chain Adjuster Ass'y	1	
3	40543-VAD-000		R. Drive Chain Adjuster	1	
4	41201-RS1-0000	22.10	Final Driven Sprocket (38T)	1	CHILD PART of 4260A-SAE-0002
5	41241-VDA-0001	1.60	Rr. Wheel Damper	4	
6	42301-SAE-0000	11.50	Rr. Wheel Axle	1	
7	42304-SAE-0000	3.00	Final Driven Side Collar	1	CHILD PART of 4260A-SAE-0002
8	42305-SAE-0002	2.40	Final Driven Inner Collar	1	CHILD PART of 4260A-SAE-0002
9	4260A-SAE-0002(X)		Final Driven Ass'y	1	PARENT PART, please order full set chil part
10	4260B-SAH-000		Rr. Wheel Sub Ass'y	1	
11	42610-VA3-0000	22.80	Final Driven Flange	1	CHILD PART of 4260A-SAE-0002
12	42620-X01-0000	3.00	Rr. Axle Distance Collar	1	
13	42653-001-0041	1.10	O-Ring 40.5x3	1	
14	42701-VD7-0000	224.60	Rr. Wheel Cast	1	

PRICE SHOWN IS PER PIECE. PRODUCT IMAGE PRICES ARE APPROXIMATE GUIDE ONLY.
PRICES SHOWN ARE SUBJECT TO CHANGE WITHOUT PRIOR NOTICE.

F-09

BÃNH SAU REAR WHEEL

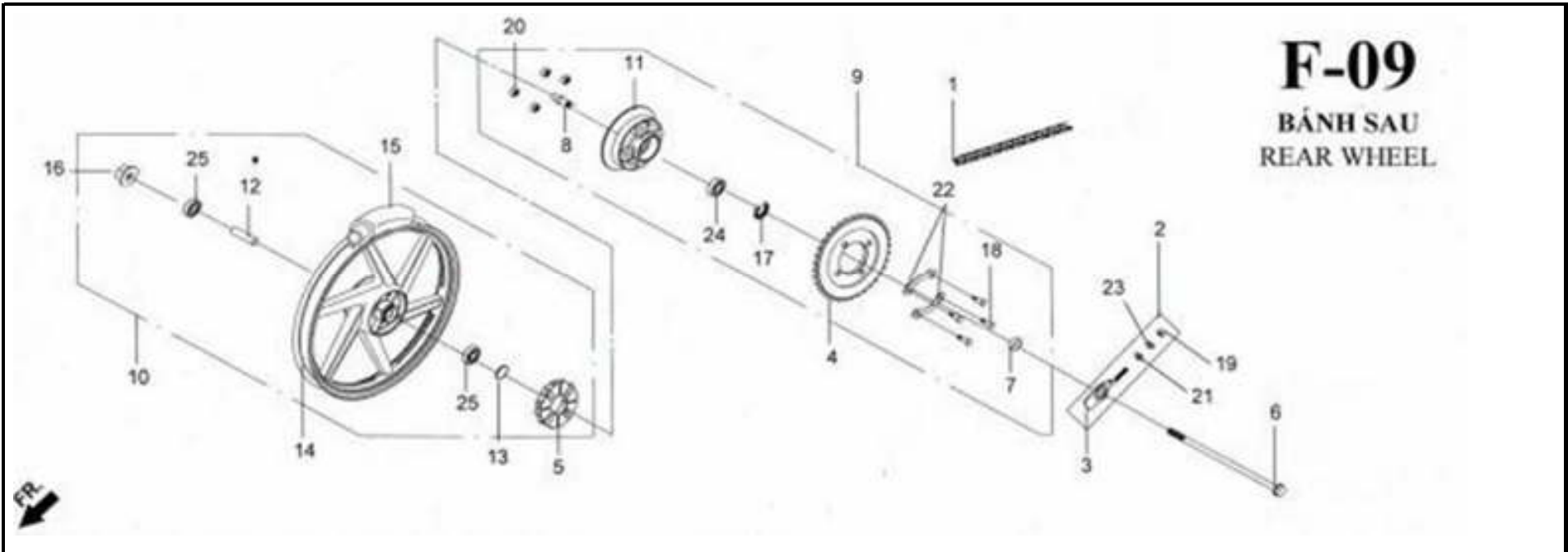

No.	VMEP CODE	(RM) Selling Price	Description	Unit	Remark
15	42710-VA2-0002(X)		Rr. Tire Ass'y	1	PARENT PART , please order full set chil part
	1TV 2.50-17 V9331 6P	PCS	Rr. Tire (SYM)	1	CHILD PART of 42710-VA2-0002
	1TV 2.50/2.75-17 TR4	PCS	Tire Tube (SYM)	1	CHILD PART of 42710-VA2-0002
16	90306-SB1-0000	PCS	Rr. Axle Nut	1	
17	90753-029-003A	PCS	Oil Seal 27x40x6	1	CHILD PART of 4260A-SAE-0002
18	92101-08032-0A	PCS	Hex Bolt 8x32	4	CHILD PART of 4260A-SAE-0002
19	94001-06000-00	PCS	Hex Nut 6 mm	1	
20	94030-08000-00	PCS	Hex Nut 8 mm	4	CHILD PART of 4260A-SAE-0002
21	94101-06000	PCS	Plain Washer 6 mm	1	
22	94108-11000-00	PCS	Tongued Washer	2	CHILD PART of 4260A-SAE-0002
23	94111-06000-00	PCS	Spring Washer 6 mm	1	
24	96100-62030-00	PCS	Radial Ball Bearing 6203Z	1	CHILD PART of 4260A-SAE-0002
25	96140-63010-10	PCS	Radial Ball Bearing 6301UU	2	

PRICE SHOWN IS PER PIECE. PRODUCT IMAGE PRICES ARE APPROXIMATE GUIDE ONLY.
PRICES SHOWN ARE SUBJECT TO CHANGE WITHOUT PRIOR NOTICE.

F-10

YÊN XE
DOUBLE SEAT

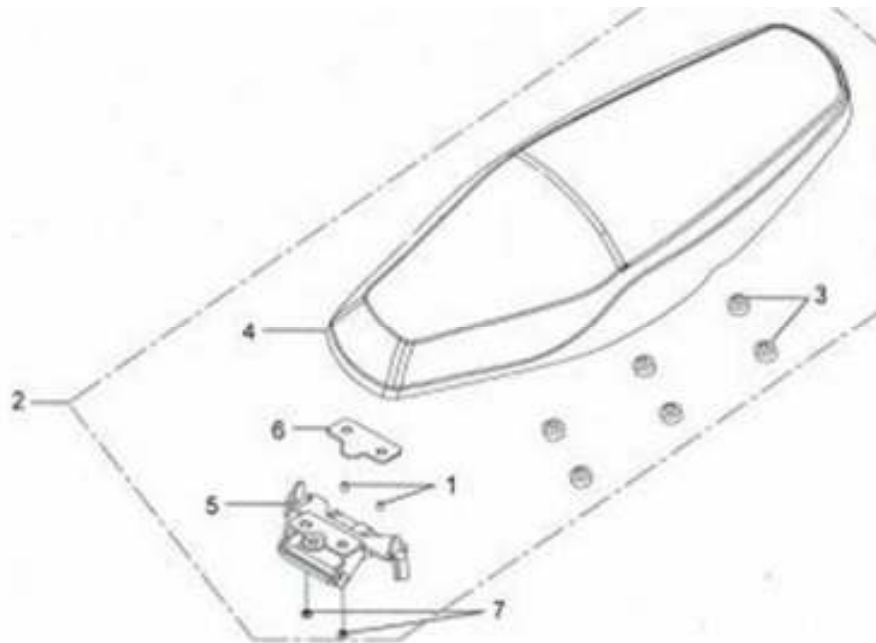

No.	VMEP CODE	(RM) Selling Price	Description	Unit	Remark
1	12396-SAE-0000	0.70	Seat Hinge Collar	2	chil part of 77200-SAH-0003
2	77200-SAH-0003	77.60	Double Seat Ass'y	1	PARENT PART
3	77206-M51-0000	1.10	Seat Stopper Rubber	6	chil part of 77200-SAH-0003
4	77210-SAH-0003(X)		Double Seat Comp.	1	chil part of 77200-SAH-0003
5	77211-SAE-0000	5.00	Seat Hinge Comp.	1	chil part of 77200-SAH-0003
6	77212-SAE-0000	1.00	Seat Hinge Rubber	1	chil part of 77200-SAH-0003
7	94050-06080	1.00	Flange Nut 6 mm	2	

PRICE SHOWN IS PER PIECE. PRODUCT IMAGE PRICES ARE APPROXIMATE GUIDE ONLY.
PRICES SHOWN ARE SUBJECT TO CHANGE WITHOUT PRIOR NOTICE.

F-11

THÙNG XĂNG FUEL TANK

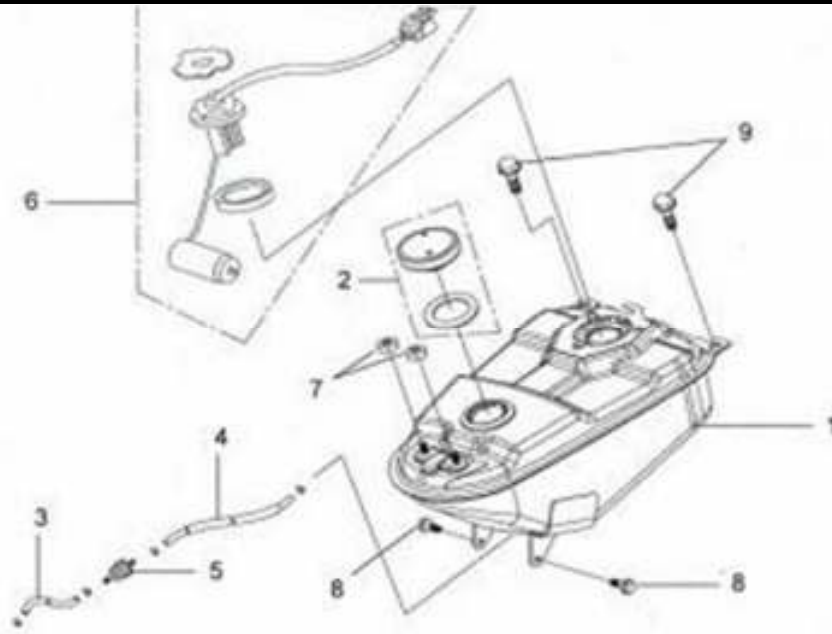

No.	VMEP CODE	(RM) Selling Price	Description	Unit	Remark
1	17500-SA5-0001	56.20	Fuel Tank Comp.	1	
2	17620-VA3-0000	18.70	Fuel Filler Cap assy.	1	
3	16802-SA5-0002	1.80	Fuel Tube 5.3x50	1	
4	16820-SB1-0000	6.70	Fuel Tube 5.3	1	
5	16920-SB1-0000	4.10	Fuel Strainer Comp.	1	
6	37800-SA1-0000	13.00	Fuel Unit Ass'y	1	
7	94050-06080	1.00	Flange Nut 6 mm	2	
8	95801-06012-00	0.40	Flange Bolt 6x12	2	
9	95801-08016-08	0.80	Flange Bolt 8x16	2	

PRICE SHOWN IS PER PIECE. PRODUCT IMAGE PRICES ARE APPROXIMATE GUIDE ONLY.
 PRICES SHOWN ARE SUBJECT TO CHANGE WITHOUT PRIOR NOTICE.

F-12

BỘ LỌC GIÓ
AIR CLEANER

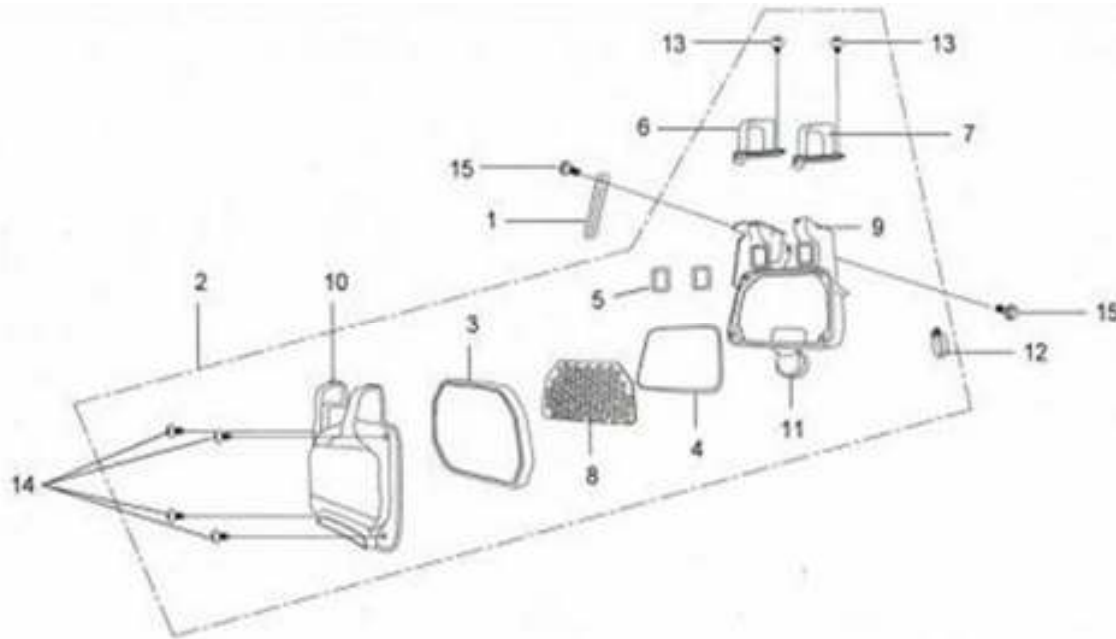

No.	VMEP CODE	(RM) Selling Price	Description	Unit	Remark
1	12342-X01-0000	1.10	Clamp	1	
2	17200-VA2-0001	39.10	Air Cleaner Ass'y	1	PARENT PART
3	17211-VA2-0000	5.40	Air Cleaner Element	1	
4	17213-VA2-0000(X)		Air Cleaner Cover Seal	1	chil part of 17200-VA2-0001
5	17214-VA2-0000(X)		Air Cleaner Case Seal	2	chil part of 17200-VA2-0001
6	17215-VA2-0000(X)		R. Duct. Cap	1	chil part of 17200-VA2-0001
7	17216-VA2-0000(X)		L. Duct. Cap	1	chil part of 17200-VA2-0001
8	17221-VA2-0000	5.60	Trap Comp.	1	
9	17230-VA2-0005(X)		Air Cleaner Case	1	chil part of 17200-VA2-0001
10	17231-VA2-0001(X)		Air Cleaner Case Cover	1	chil part of 17200-VA2-0001
11	17253-VA2-0000	4.10	Air Cleaner Connecting Tube	1	
12	17255-VA2-0000	1.80	Air Cleaner Connecting Tube Band B	1	
13	93901-24310	0.60	Tapping Screw 4x12	2	chil part of 17200-VA2-0001
14	93903-25410	0.60	Tapping Screw 5x20	4	chil part of 17200-VA2-0001
15	95801-06012-00	0.40	Flange Bolt 6x12	2	

PRICE SHOWN IS PER PIECE. PRODUCT IMAGE PRICES ARE APPROXIMATE GUIDE ONLY.
PRICES SHOWN ARE SUBJECT TO CHANGE WITHOUT PRIOR NOTICE.

F-13

ÔNG XẢ
EXHAUST MUFFLER

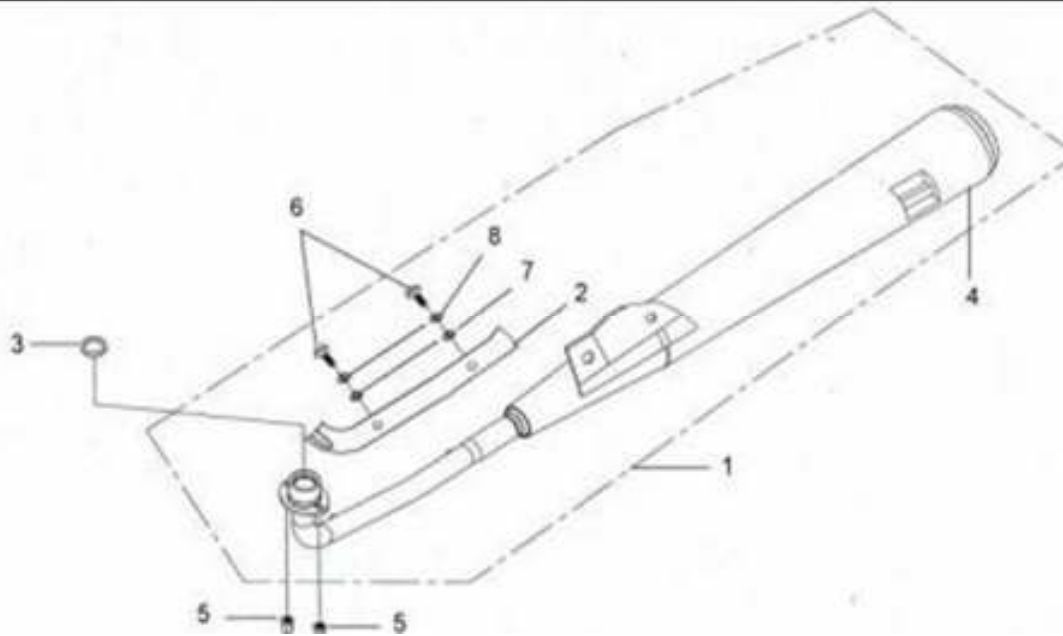

No.	VMEP CODE	(RM) Selling Price	Description	Unit	Remark
1	18000-SAE-0001	114.10	Muffler Ass'y	1	PARENT PART
2	18240-SA5-0000	10.20	Exhaust Pipe Protector	1	chil part of 18000-SAE-0001
3	18291-X01-0000	1.60	Exhaust Pipe Gasket	1	
4	18300-SAE-0001		Exhaust Muffler Comp.	1	chil part of 18000-SAE-0001
5	90308-M36-0000	1.10	Cap Nut 6mm	2	
6	93500-05008-OA	0.40	Pan Screw 5x8	2	
7	94101-05000	0.40	Plain Washer 5mm	2	chil part of 18000-SAE-0001
8	94111-05000	0.40	Spring Washer 5mm	2	chil part of 18000-SAE-0001

PRICE SHOWN IS PER PIECE. PRODUCT IMAGE PRICES ARE APPROXIMATE GUIDE ONLY.
PRICES SHOWN ARE SUBJECT TO CHANGE WITHOUT PRIOR NOTICE.

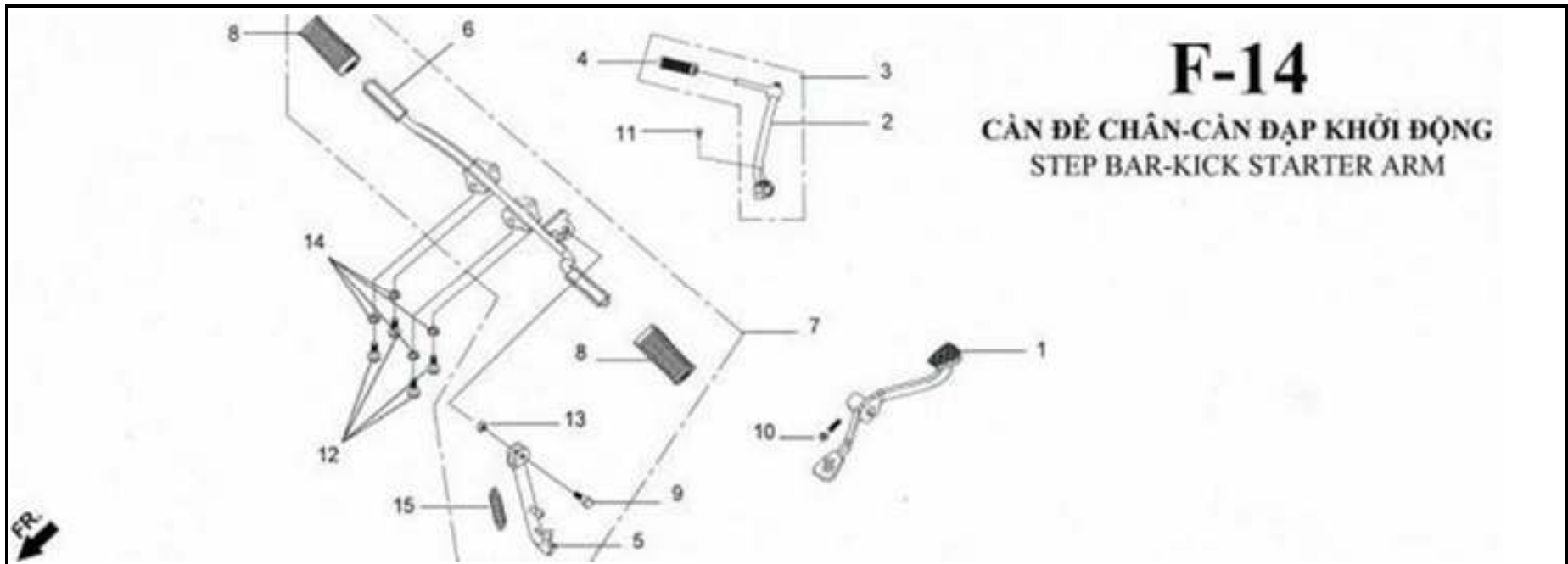

No.	VMEP CODE	(RM) Selling Price	Description	Unit	Remark
1	24701-SA5-9000	14.90	Gear Change Pedal	1	
2	28300-SB7-0000(X)		Kick Starter Arm	1	chil part of 2830A-SB7-0000
3	2830A-SB7-0000	26.20	Kick Starter Arm Set	1	PARENT PART
4	28311-SB7-0000(X)		Kick Starter Rubber	1	chil part of 28300-SB7-0000
5	50530-VA3-0000	7.80	Side Stand Bar Comp.	1	CHIL PART of 5061A-VB4-0002
6	50610-SAE-0001	29.90	Step Bar Comp.	1	CHIL PART of 5061A-VB4-0002
7	5061A-VB4-0002(X)		Step Bar Ass'y	1	PARENT PART, please order full set chil part
8	50661-VB4-0000	3.20	Step Rubber	2	CHIL PART of 5061A-VB4-0002
9	90108-B06-0001	1.60	Side Stand Pivot Screw	1	CHIL PART of 5061A-VB4-0002
10	92101-06020-0A	0.50	Hex Bolt 6x20	1	
11	92101-06028-0H	0.60	Hex Bolt 6x28	1	
12	92101-08020-0A	0.70	Hex Bolt 8x20	4	
13	94002-10080-0S	0.70	Hex Nut 10mm	1	CHIL PART of 5061A-VB4-0002
14	94111-08000	0.50	Spring Washer 8 mm	4	
15	95014-72102-OB	2.20	Side Stand Spring	1	CHIL PART of 5061A-VB4-0002

PRICE SHOWN IS PER PIECE. PRODUCT IMAGE PRICES ARE APPROXIMATE GUIDE ONLY.
 PRICES SHOWN ARE SUBJECT TO CHANGE WITHOUT PRIOR NOTICE.

F-15

CHÔNG ĐỨNG-BÀN ĐẠP
THĂNG
MAIN STAND BRAKE PEDAL

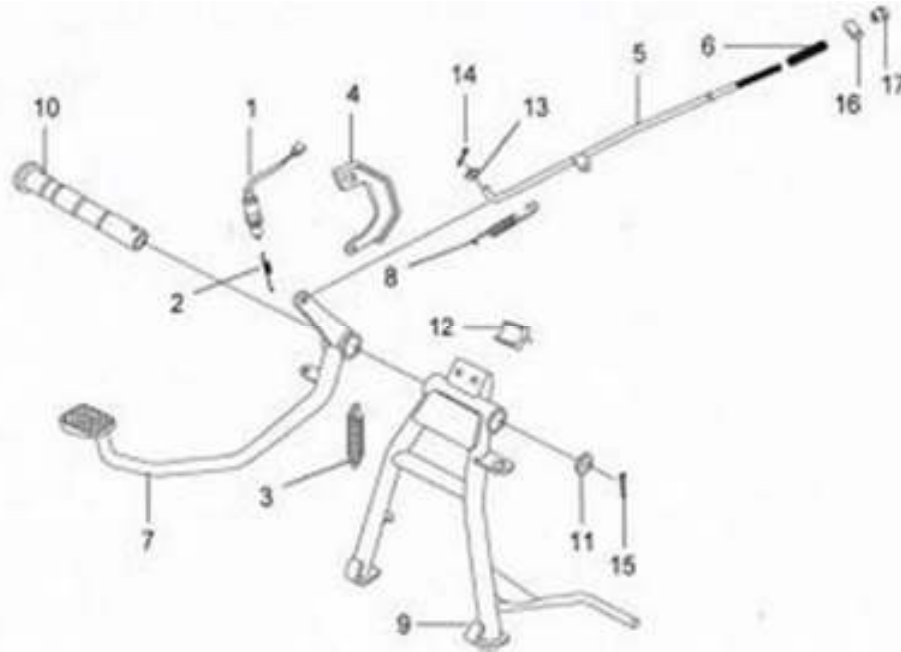

No.	VMEP CODE	(RM) Selling Price	Description	Unit	Remark
1	35350-SA5-0001	5.60	Stop Switch Ass'y	1	
2	35357-SA5-0001	1.10	Stop Switch Spring	1	
3	42242-SA1-0000	2.20	Main Stand Spring	1	
4	42246-SA1-0000	2.00	Main Stand Spring Hook	1	
5	43450-SAH-0000	4.50	Rr. Brake Rod	1	
6	43550-SB1-0000	0.60	Rr. Brake Rod Spring	1	
7	46500-SA5-0001	14.70	Rr. Brake Pedal Comp.	1	
8	46513-SA1-0000	1.10	Rr. Brake Return Spring	1	
9	50500-SA6-0000	12.00	Main Stand Comp.	1	
10	50520-SA1-0001	4.90	Main Stand Pivot Bolt	1	
11	50521-SA1-0000	0.70	Main Stand Pivot Washer	1	
12	50524-SA1-0000	1.10	Main Stand Stopper Rubber	1	
13	94101-05000	0.40	Plain Washer 5mm	1	
14	94201-20151	0.70	Split Pin 2.0x15	1	
15	94201-30280	0.70	Split Pin 3.0	1	
16	95015-32001-00	0.70	Brake Arm Joint B	1	
17	95015-42000-00	2.10	Adjust Nut B	1	

PRICE SHOWN IS PER PIECE. PRODUCT IMAGE PRICES ARE APPROXIMATE GUIDE ONLY.
PRICES SHOWN ARE SUBJECT TO CHANGE WITHOUT PRIOR NOTICE.

F-16

GÁP SAU-HỘP XÍCH TÀI REAR FORK-CHAIN CASE

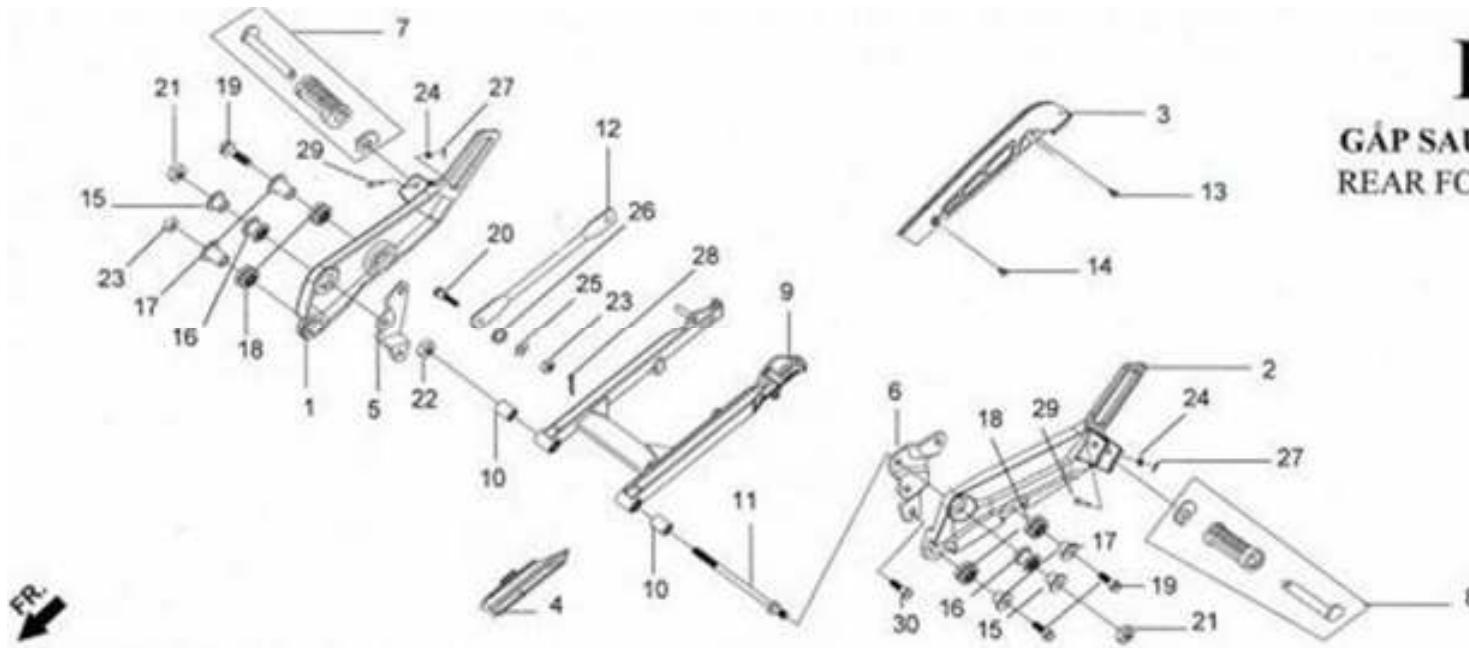

No.	VMEP CODE	(RM) Selling Price	Description	Unit	Remark
1	18325-SA6-0000-IC	41.30	R. Step Holder	1	
2	18425-SA6-0000-IC	37.50	L. Step Holder	1	
3	4051A-SA5-0000	19.50	Drive Chain Guard	1	
4	40591-SA5-0001	2.60	Drive Chain Case Packing	1	
5	50713-SA1-0000	6.70	R. Pillion Step Stay	1	
6	50714-SA5-0000	6.40	L. Pillion Step Stay	1	
7	50830-SAE-0001	5.60	R. Pillion Step Bar Ass'y	1	
8	50840-SAE-0001	5.60	L. Pillion Step Bar Ass'y	1	
9	52100-SAE-0001-IC	74.90	Rr. Fork Comp.	1	
10	52181-A08-3000	5.60	Rr. Fork Pivot Rubber Bush	2	
11	61251-SA1-0000	6.00	Rr. Fork Pivot Bolt	1	
12	65311-SA1-0000	3.90	Rr. Brake Stopper Arm	1	
13	90111-M9Q-9000	0.70	Flange Bolt 6mm	1	
14	90112-M67-0000	0.70	Flange Bolt 6mm	1	
15	90116-SA1-0000	0.80	Pillion Collar 10x8	2	
16	90117-SA1-0000	0.30	Pillion Rubber 10	2	

PRICE SHOWN IS PER PIECE. PRODUCT IMAGE PRICES ARE APPROXIMATE GUIDE ONLY.
PRICES SHOWN ARE SUBJECT TO CHANGE WITHOUT PRIOR NOTICE.

F-16

GẮP SAU-HỘP XÍCH TÀI REAR FORK-CHAIN CASE

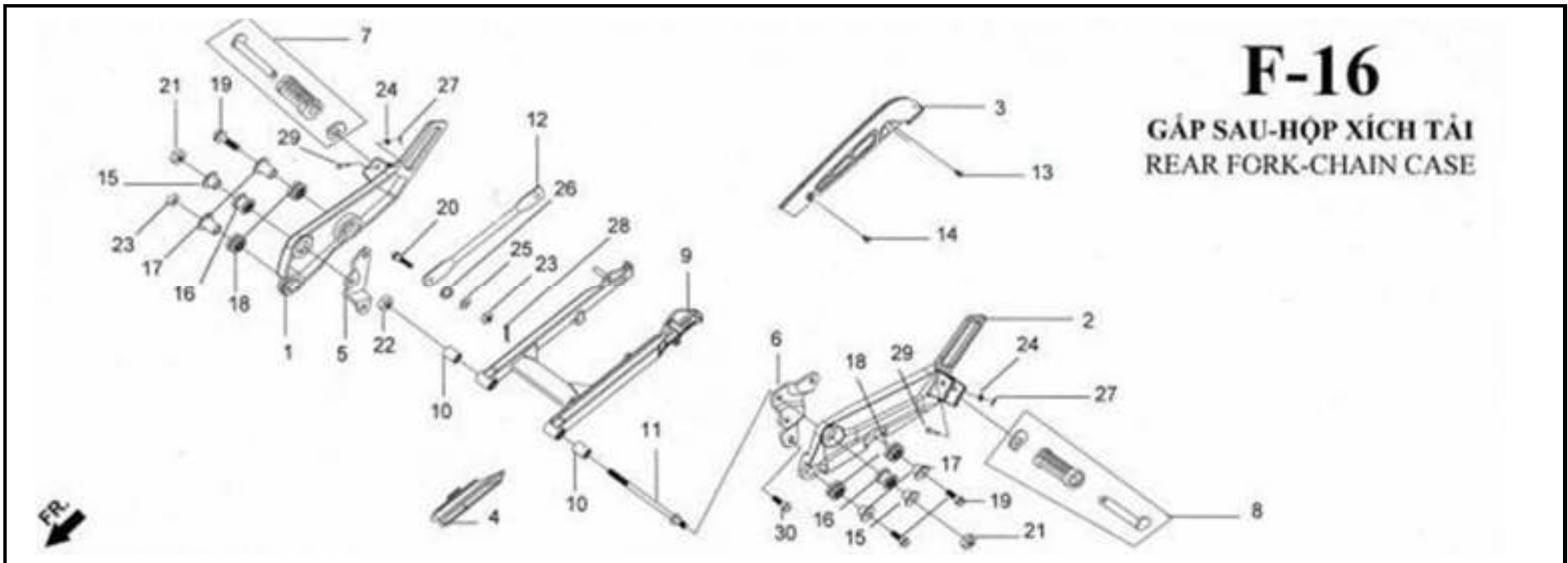

No.	VMEP CODE	(RM) Selling Price	Description	Unit	Remark
17	90118-SA1-0000	0.50	Pillion Collar 8x12	4	
18	90119-SA1-0000	0.30	Pillion Rubber 8	4	
19	92101-08028-0A	0.70	Hex Bolt 8x28	3	
20	92812-10000	1.50	Rr. Brake Stopper Arm Bolt	1	
21	94001-10000-0S	0.70	Hex Nut 10mm	2	
22	94002-10000-0S	0.70	Hex Nut 10mm	1	
23	94050-08000	0.70	Flange Nut 8mm	2	
24	94101-06000	0.40	Plain Washer 6mm	2	
25	94101-08000	0.50	Plain Washer 8mm	1	
26	94111-10000-00	0.70	Spring Washer 10mm	1	
27	94201-16150	0.70	Split Pin 1.6x15	2	
28	94201-20151	0.70	Split Pin 2.0x15	1	
29	95015-83000	0.70	Pillion Step Pin	2	
30	95801-08016-08	0.80	Flange Bolt 8x16	2	

PRICE SHOWN IS PER PIECE. PRODUCT IMAGE PRICES ARE APPROXIMATE GUIDE ONLY.
PRICES SHOWN ARE SUBJECT TO CHANGE WITHOUT PRIOR NOTICE.

F-17

BỘ PHỤC SAU
REAR CUSHION

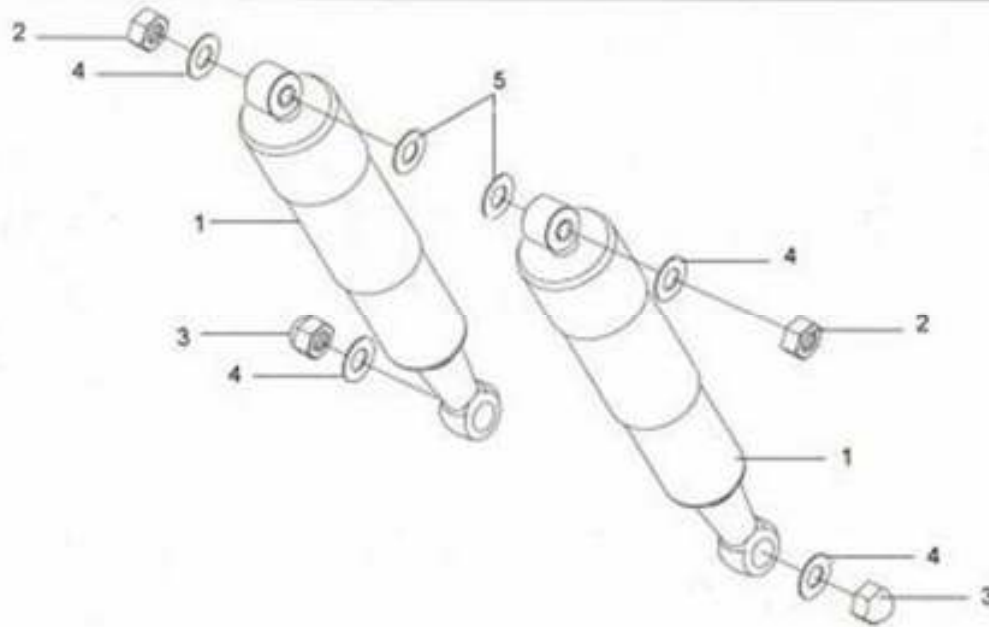

No.	VMEP CODE	(RM) Selling Price	Description	Unit	Remark
1	52400-SAE-0002	71.70	Rear Cushion Ass'y	2	
2	94001-10000-0S	0.70	Hex Nut 10 mm	2	
3	94021-10000	2.00	Hex Cap Nut 10 mm	2	
4	94101-10000-00	0.60	Plain Washer 10 mm	4	
5	94101-12000-00	0.60	Plain Washer 12 mm	2	

PRICE SHOWN IS PER PIECE. PRODUCT IMAGE PRICES ARE APPROXIMATE GUIDE ONLY.
PRICES SHOWN ARE SUBJECT TO CHANGE WITHOUT PRIOR NOTICE.

F-18

ÓP SƯỜN

BODY COVER

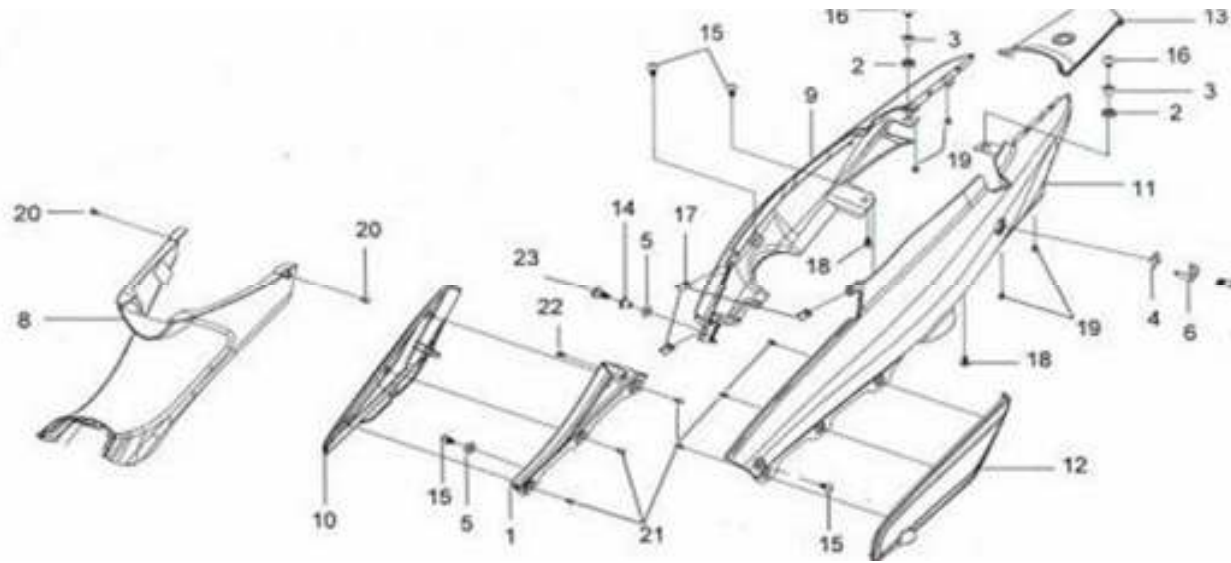

No.	VMEP CODE	(RM) Selling Price	Description	Unit	Remark
1	50326-SA5-0001-KB	4.80	Battery Cover (black)	1	
	50326-SA5-0001-RE	4.80	Battery Cover (red)	1	
	50326-SA5-0001-BH1	4.80	Battery Cover (blue)	1	
	50326-SA5-0001-WF	4.80	Battery Cover (white)	1	
	50326-SA5-0001-YL	4.80	Battery Cover (orange)	1	
2	64304-X01-0000	0.70	Fr. Cover Rubber	2	
3	64306-X01-0000	0.70	Fr. Cover Collar	2	
4	75581-M9Q-0001	3.20	Lock Key Set Spring	1	
5	77226-M3F-0000	0.40	Damping Rubber	2	
6	77232-F3C-0002	1.90	Seat Lock Stay	1	
7	77239-SA5-0000	21.20	Seat Lock Comp.	1	CHILD PART of 35010-SA5-0000, F03-8
8	80152-SA5-0000	12.10	Center Cover	1	
9	83500-SA5-0004-KB	38.70	R. Body Cover (black)	1	
	83500-SA5-0004-RB	38.70	R. Body Cover (red)	1	
	83500-SA5-0004-DH	38.70	R. Body Cover (blue)	1	
	83500-SA5-0004-WF	38.70	R. Body Cover (white)	1	
	83500-SA5-0004-YL	38.70	R. Body Cover (yellow)	1	
10	83550-SA5-0000-IF	16.30	R. Side Plate	1	
11	83600-SA5-0004-KB	38.70	L. Body Cover (black)	1	
	83600-SA5-0004-RB	38.70	L. Body Cover (red)	1	

PRICE SHOWN IS PER PIECE. PRODUCT IMAGE PRICES ARE APPROXIMATE GUIDE ONLY.
 PRICES SHOWN ARE SUBJECT TO CHANGE WITHOUT PRIOR NOTICE.

F-18

ÓP SƯỜN

BODY COVER

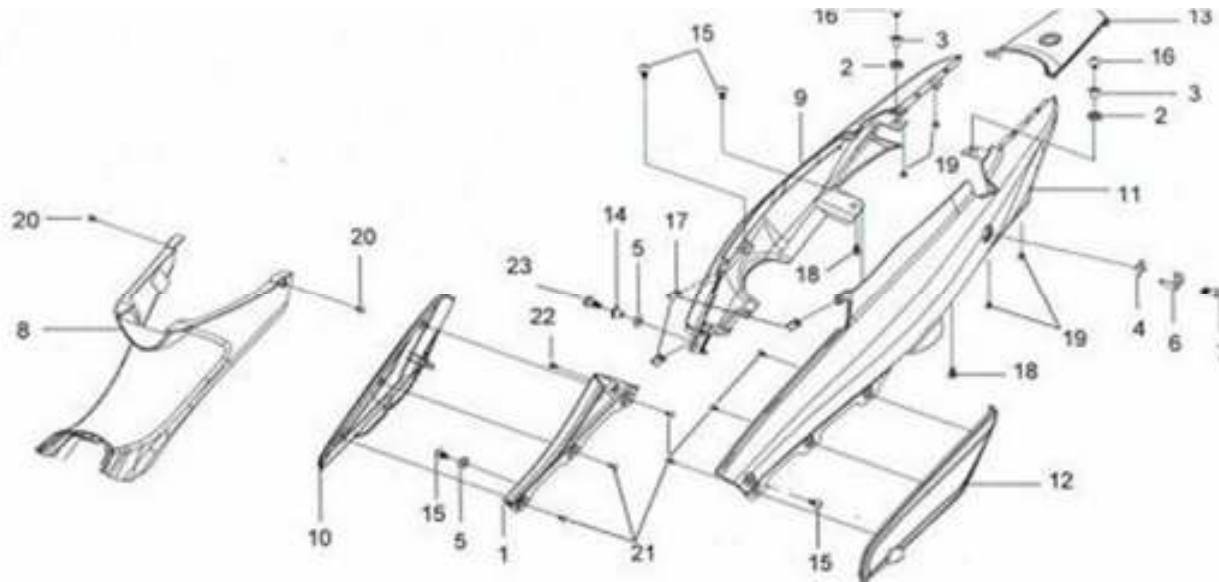

No.	VMEP CODE	(RM) Selling Price	Description	Unit	Remark
	83600-SA5-0004-DH	38.70	L. Body Cover (blue)	1	
	83600-SA5-0004-WF	38.70	L. Body Cover (white)	1	
	83600-SA5-0004-YL	38.70	L. Body Cover (yellow)	1	
12	83650-SA5-0000-IF	16.30	L. Side Plate	1	
13	87123-SA5-0002-KB	7.50	Rr. Center Cover (black)	1	
	87123-SA5-0002-RB	7.50	Rr. Center Cover (red)	1	
	87123-SA5-0002-DH	7.50	Rr. Center Cover (blue)	1	
	87123-SA5-0002-WF	7.50	Rr. Center Cover (white)	1	
	87123-SA5-0002-YL	7.50	Rr. Center Cover (yellow)	1	
14	90104-VA1-0000	0.70	Fr. Fork Cover Collar	1	
15	90110-GZ0-000A	0.70	Special Screw 6mm	4	
16	90115-VA3-0000	1.10	Body Cover Bolt 6x18	2	
17	90302-SA4-003B	0.70	Spring Nut 4mm	3	
18	93404-06012-00	0.60	Washer Bolt 6x12	2	
19	93903-24220-10	0.60	Tapping Screw 4x10	4	
20	93903-24380	0.60	Tapping Screw 4x12	2	
21	93903-34320-00	0.60	Tapping Screw 4x12	6	
22	93903-44480	0.60	Tapping Screw 4x16	1	
23	95801-06016-08	1.00	Flange Bolt 6x16	1	

PRICE SHOWN IS PER PIECE. PRODUCT IMAGE PRICES ARE APPROXIMATE GUIDE ONLY.
 PRICES SHOWN ARE SUBJECT TO CHANGE WITHOUT PRIOR NOTICE.

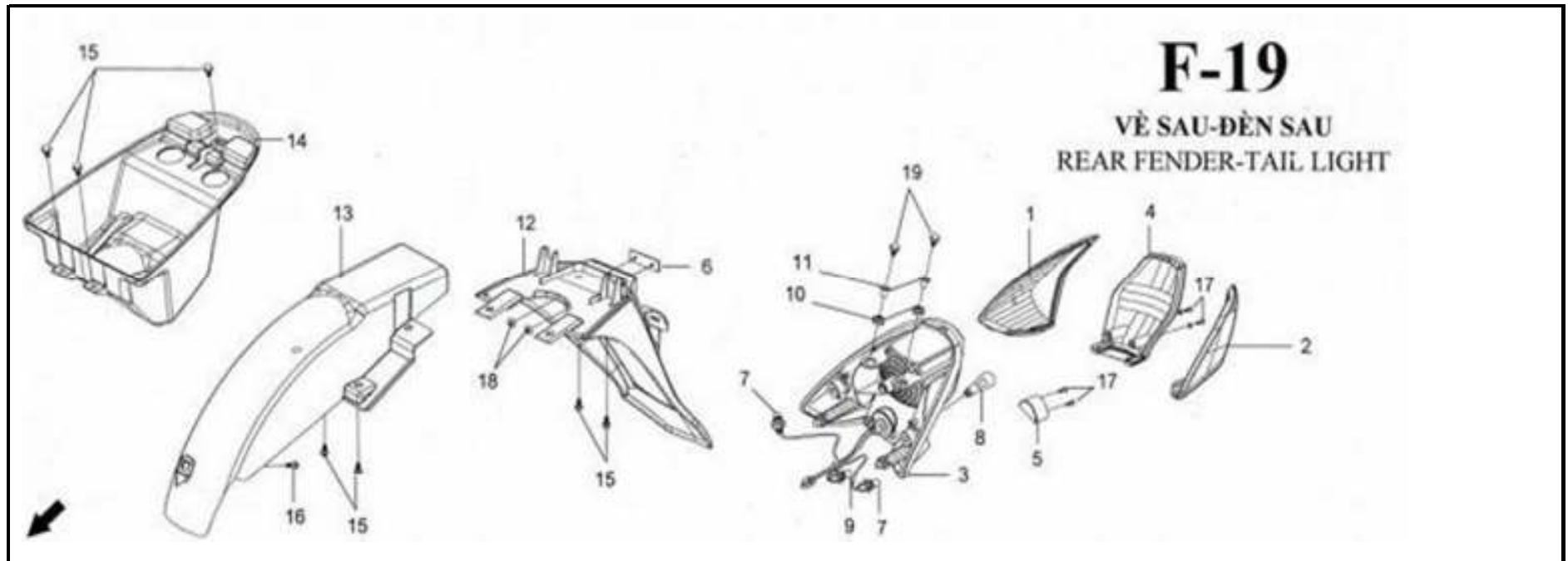

F-19

VỀ SAU-ĐÈN SAU
REAR FENDER-TAIL LIGHT

No.	VMEP CODE	(RM) Selling Price	Description	Unit	Remark
1	33602-SA5-0001	5.20	Rr. R. Winker Lens	1	
2	33652-SA5-0001	5.20	Rr. L. Winker Lens	1	
3	33701-SA5-0001	18.70	Tail Light Base	1	
4	33702-SA5-0000	13.80	Tail Light Lens	1	
5	33705-SA5-0000	5.20	Licence Lens	1	
6	33741-E51-0001	4.90	Rr. Reflector	1	
7	34905-M9Q-0000	2.90	Winker Bulb	2	
8	34906-M9Q-0000	13.10	Tail Light Bulb	1	
9	34908-M9Q-0000	1.50	Rr. Licence Bulb	1	
10	64304-X01-0000	0.70	Fr. Cover Rubber	2	
11	64306-X01-0000	0.70	Fr. Cover Collar	2	
12	80100-SA5-0000	15.10	Rr. Fender	1	
13	80200-SA5-0001	9.10	Rr. Center Fender	1	
14	83400-SA5-0000	11.40	Tool Box	1	
15	90111-VA2-0000	0.70	Flange Bolt 6mm	7	
16	93404-06016-00	0.80	Washer Bolt 6x16	1	
17	93901-34320	0.60	Tapping Screw 4x12	4	
18	94050-05080-00	0.70	Flange Nut 5mm	2	
19	95801-06020-00	0.70	Flange Bolt 6x20	2	

PRICE SHOWN IS PER PIECE. PRODUCT IMAGE PRICES ARE APPROXIMATE GUIDE ONLY.
PRICES SHOWN ARE SUBJECT TO CHANGE WITHOUT PRIOR NOTICE.

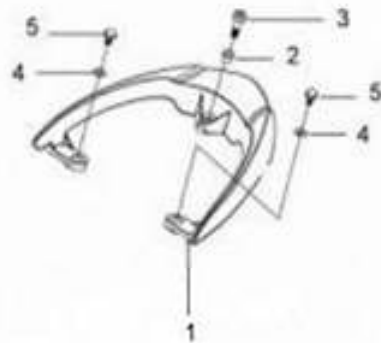

F-20

TAY NĂM
REAR CARRIER



No.	VMEP CODE	(RM) Selling Price	Description	Unit	Remark
1	81200-SA5-9000	24.20	Rr. Carrier	1	
2	81204-H6T-0000	3.90	Rr. Carrier Collar	1	
3	90186-VA6-0001	2.30	Socket Bolt 8x25	1	
4	94103-08000	0.50	Plain Washer 8mm	2	
5	95801-08020-00	1.10	Flange Bolt 8x20	2	

PRICE SHOWN IS PER PIECE. PRODUCT IMAGE PRICES ARE APPROXIMATE GUIDE ONLY.
 PRICES SHOWN ARE SUBJECT TO CHANGE WITHOUT PRIOR NOTICE.

F-21

DÂY ĐIỆN - BÌNH ĐIỆN
WIRE HARNESS - BATTERY

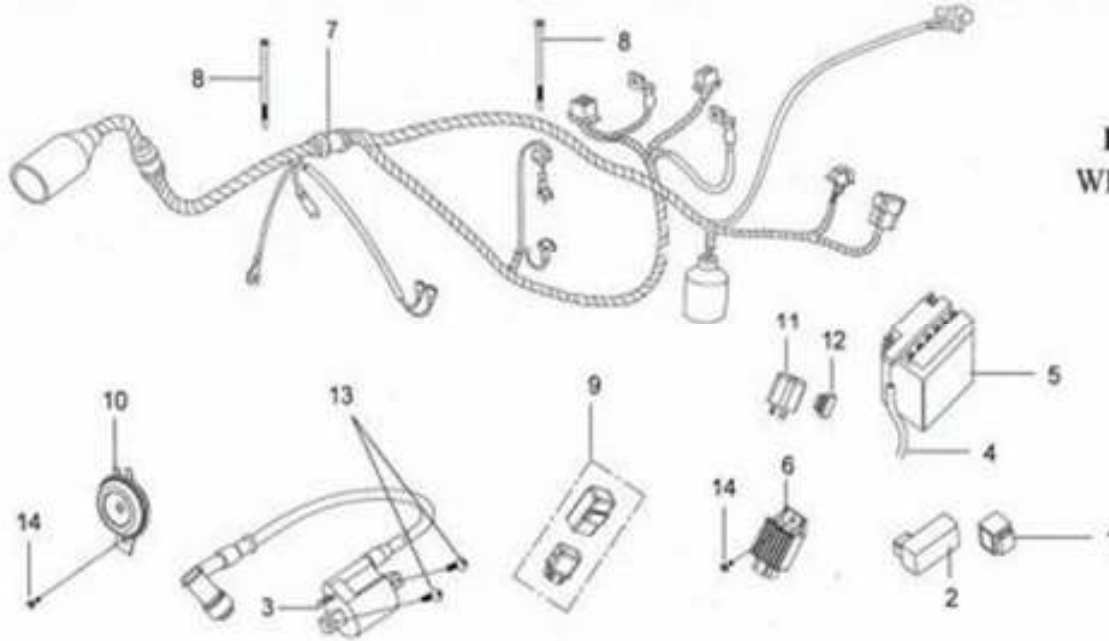

No.	VMEP CODE	(RM) Selling Price	Description	Unit	Remark
1	30400-SA5-0000	30.00	C.D.I Unit Cushion	1	
2	30410-SA5-000		C.D.I Unit Comp.	1	please order 30400-SA5-0000
3	30500-SA5-0000	26.10	Ignition Coil Ass'y	1	
4	31502-VA3-0000	2.10	Battery Breather Tube	1	
5	1BL 12N5-3B	63.60	Battery Set	1	
6	31600-VN7-0000	41.20	Regulator Rectifier Comp.	1	
7	32100-SA5-0002	44.90	Wire Harness	1	
8	32161-T15-000		Wire Band 250	2	
9	34600-SA1-0000	13.00	Start Relay Ass'y	1	
10	38110-SA5-0003	11.20	Horn Comp.	1	
11	38201-SA1-0000(X)		Winker Relay Comp.	1	please order parent part, 38200-SA1-0000
12	38206-SA1-0000(X)		Winker Relay Rubber	1	please order parent part, 38200-SA1-0000
13	93500-05016-0H	0.40	Pan Screw 5x16	2	
14	95801-06012-00	0.40	Flange Bolt 6x12	2	

PRICE SHOWN IS PER PIECE. PRODUCT IMAGE PRICES ARE APPROXIMATE GUIDE ONLY.
PRICES SHOWN ARE SUBJECT TO CHANGE WITHOUT PRIOR NOTICE.

F-22

KHUNG XE
FRAME BODY

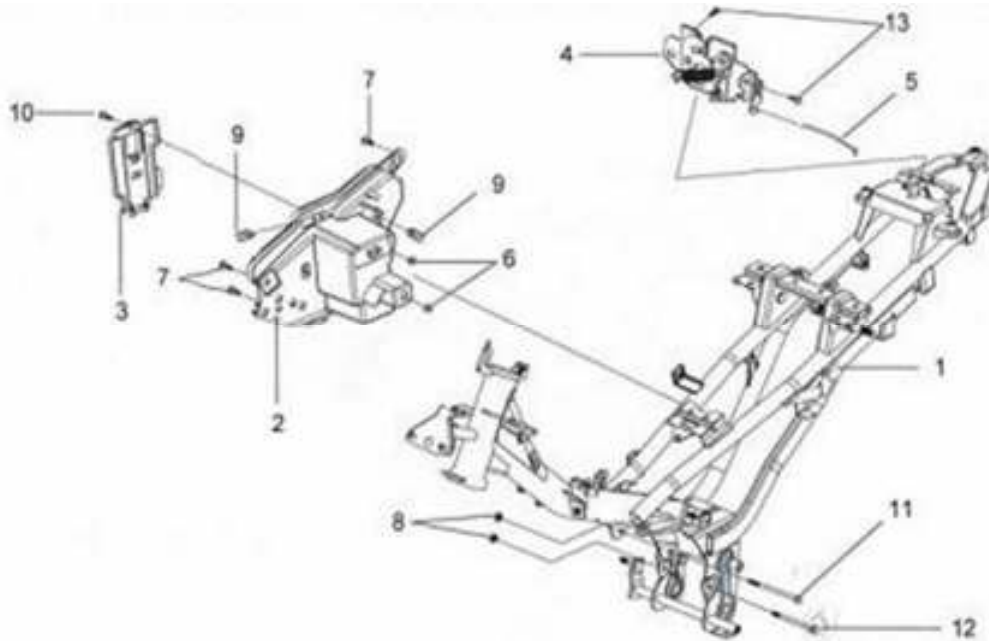

No.	VMEP CODE	(RM) Selling Price	Description	Unit	Remark
1	50100-SAE-0000	500.00	Frame Body Comp.	1	
2	50320-SA5-0000	7.20	Battery Case	1	
3	50322-SA5-0000	7.20	Battery Tray	1	
4	77230-SA5-0000	12.30	Seat Catch Comp.	1	
5	77240-SA5-0001	4.00	Seat Lock Cable	1	
6	83551-SB1-0000	0.40	Side Cover Grommet	2	
7	90111-VA2-0000	0.70	Flange Bolt 6 mm	3	
8	90309-M9Q-0000	1.90	Flange Nut 8 mm	2	
9	90344-SA1-0000	0.20	Special Clip 6 mm	2	
10	93891-06016-07	0.60	Washer Screw 6x16	1	
11	95301-08100-00	2.00	Engine Hanger Under Bolt 8x100	1	
12	95301-08110-00	2.00	Engine Hanger Upper Bolt 8x110	1	
13	95801-06012-00	0.40	Flange Bolt 6x12	2	

PRICE SHOWN IS PER PIECE. PRODUCT IMAGE PRICES ARE APPROXIMATE GUIDE ONLY.
PRICES SHOWN ARE SUBJECT TO CHANGE WITHOUT PRIOR NOTICE.

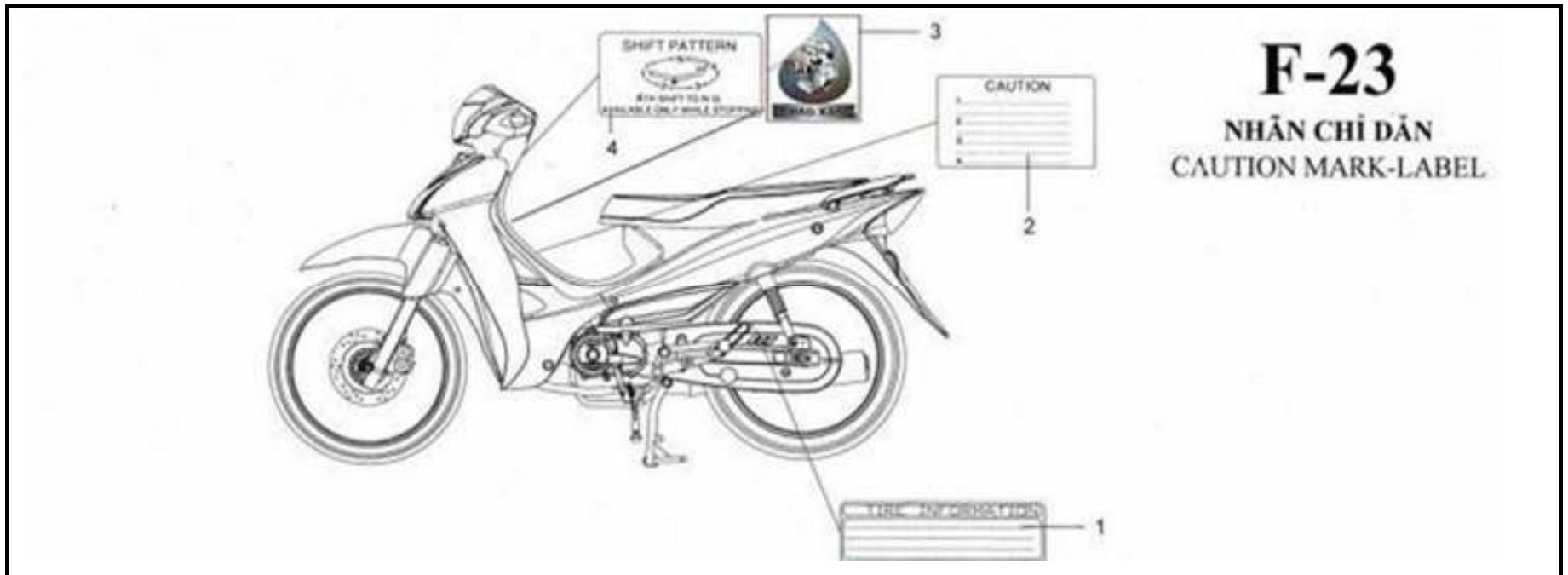

F-23

NHÃN CHỈ DẪN
CAUTION MARK-LABEL

No.	VMEP CODE	(RM) Selling Price	Description	Unit	Remark
1	87505-X01-0001-L1	0.70	Tire Caution Mark	1	
2	87508-VR3-0000	0.40	Air Cleaner Caution Label	1	
3	87510-KAG-0000	2.00	Economy Fuel Label	1	
4	87512-VA2-0000	2.00	Shift Pattern Label	1	

PRICE SHOWN IS PER PIECE. PRODUCT IMAGE PRICES ARE APPROXIMATE GUIDE ONLY.
PRICES SHOWN ARE SUBJECT TO CHANGE WITHOUT PRIOR NOTICE.

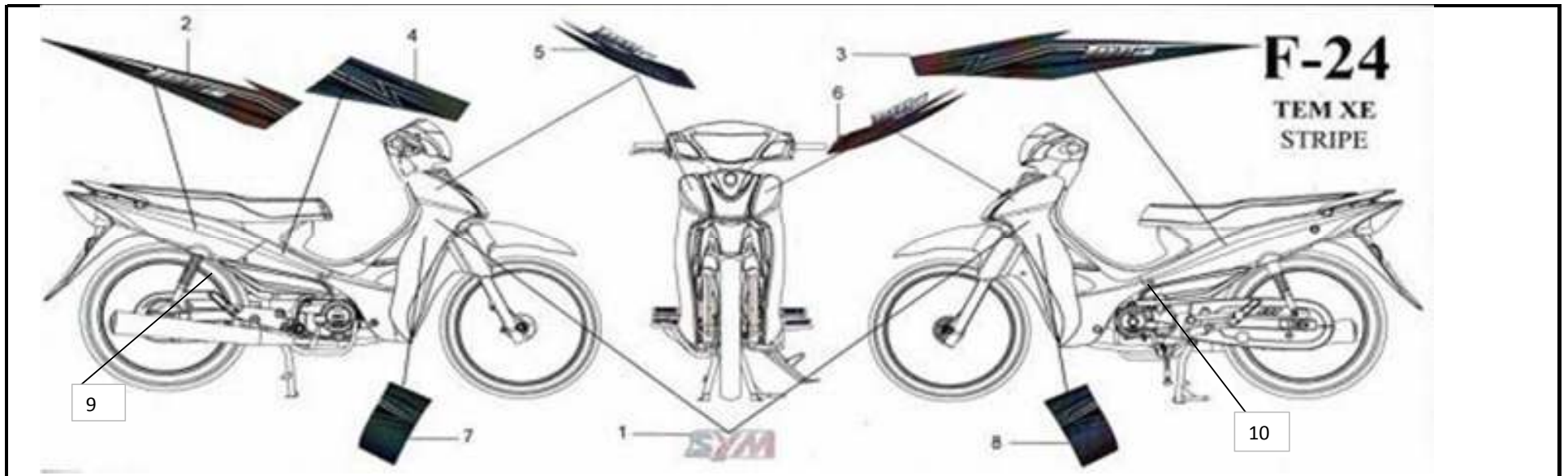

No.	VMEP CODE	(RM) Selling Price	Description	Unit	Remark
1	83503-SAH-0000-T1	0.70	SYM Stripe	2	T1
2	87121-SAH-0001-T1	15.60	R. Body Cover Stripe (BLACK)	1	
	87121-SAH-0001-T2	15.60	R. Body Cover Stripe (RED)	1	
	87121-SAH-0001-T3	15.60	R. Body Cover Stripe (WHITE)	1	
	87121-SAH-0001-T4	15.60	R. Body Cover Stripe (ORANGE)	1	
	87121-SAH-0000-T5	15.60	R. Body Cover Stripe (BLUE)	1	
3	87122-SAH-0000-T1	15.60	L. Body Cover Stripe (BLACK)	1	
	87122-SAH-0001-T2	15.60	L. Body Cover Stripe (RED)	1	
	87122-SAH-0001-T3	15.60	L. Body Cover Stripe (WHITE)	1	
	87122-SAH-0000-T4	15.60	L. Body Cover Stripe (ORANGE)	1	
	87122-SAH-0000-T5	15.60	L. Body Cover Stripe (BLUE)	1	
4	87127-SAH-0000-T1	5.20	Battery Cover Stripe (BLACK)	1	
	87127-SAH-0000-T2	5.20	Battery Cover Stripe (RED)	1	
	87127-SAH-0001-T3	5.20	Battery Cover Stripe (WHITE)	1	
	87127-SAH-0001-T4	5.20	Battery Cover Stripe (ORANGE)	1	
	87127-SAH-0000-T5	5.20	Battery Cover Stripe (BLUE)	1	
5	87133-SAH-0000-T1	3.70	R. Front Cover Stripe A (BLACK)	1	
	87133-SAH-0001-T2	3.70	R. Front Cover Stripe A (RED)	1	
	87133-SAH-0002-T3	3.70	R. Front Cover Stripe A (WHITE)	1	
	87133-SAH-0002-T4	3.70	R. Front Cover Stripe A (ORANGE)	1	
	87133-SAH-0002-T5	3.70	R. Front Cover Stripe A (BLUE)	1	

PRICE SHOWN IS PER PIECE. PRODUCT IMAGE PRICES ARE APPROXIMATE GUIDE ONLY.
 PRICES SHOWN ARE SUBJECT TO CHANGE WITHOUT PRIOR NOTICE.

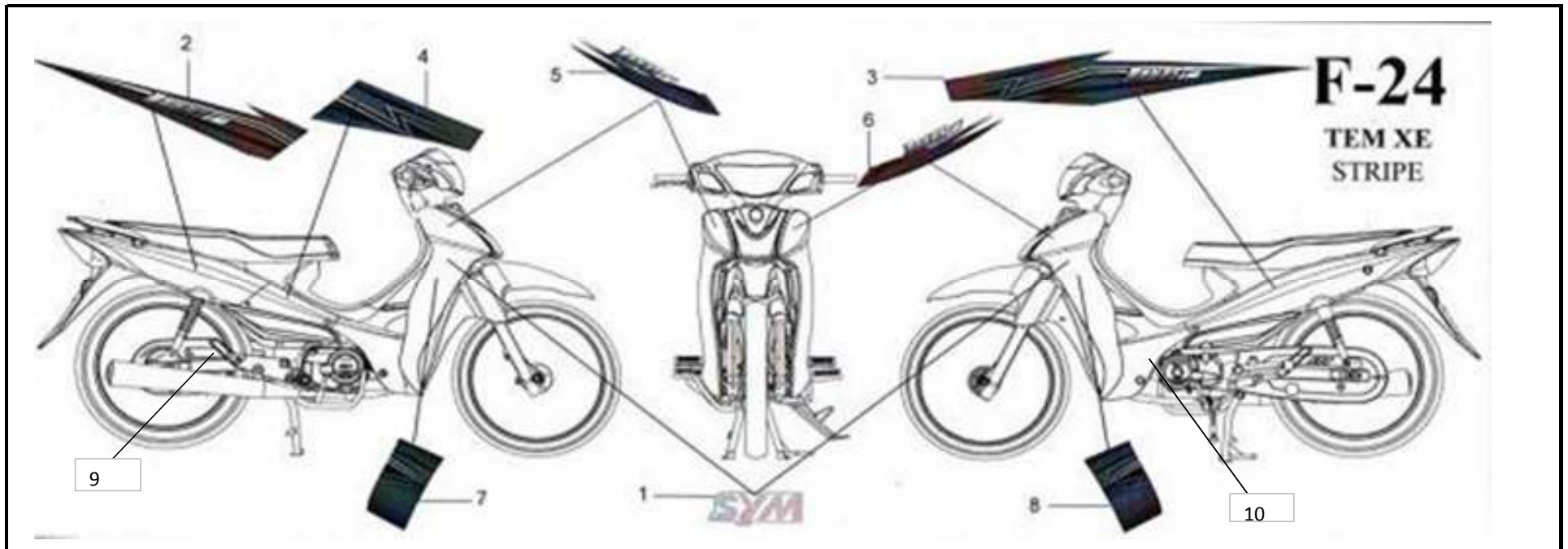

No.	VMEP CODE	(RM) Selling Price	Description	Unit	Remark
6	87134-SAH-0000-T1	3.70	L. Front Cover Stripe A (BLACK)	1	
	87134-SAH-0001-T2	3.70	L. Front Cover Stripe A (RED)	1	
	87134-SAH-0001-T3	3.70	L. Front Cover Stripe A (WHITE)	1	
	87134-SAH-0001-T4	3.70	L. Front Cover Stripe A (ORANGE)	1	
	87134-SAH-0000-T5	3.70	L. Front Cover Stripe A (BLUE)	1	
7	87135-SAH-0000-T1	4.70	R. Front Cover Stripe B (BLACK)	1	
	87135-SAH-0001-T2	4.70	R. Front Cover Stripe B (RED)	1	
	87135-SAH-0001-T3	4.70	R, Front Cover Stripe B (WHITE)	1	
	87135-SAH-0001-T4	4.70	R. Front Cover Stripe B (ORANGE)	1	
	87135-SAH-0000-T5	4.70	R. Front Cover Stripe B (BLUE)	1	
8	87136-SAH-0000-T1	4.70	L. Front Cover Stripe B (BLACK)	1	
	87136-SAH-0001-T2	4.70	L. Front Cover Stripe B (RED)	1	
	87136-SAH-0001-T3	4.70	L. Front Cover Stripe B (WHITE)	1	
	87136-SAH-0001-T4	4.70	L. Front Cover Stripe B (ORANGE)	1	
	87136-SAH-0000-T5	4.70	L. Front Cover Stripe B (BLUE)	1	
9	87125-SAH-0000-T5	5.40	R. Main Pipe Cover Stripe (BLUE)	1	
10	87126-SAH-0000-T5	5.40	L. Main Pipe Cover Stripe (BLUE)	1	
11	87000-SAH-0000-T1	54.90	STRIPE SET		T1-BLACK, T2-RED, T3-WHITE T4-BLUE

PRICE SHOWN IS PER PIECE. PRODUCT IMAGE PRICES ARE APPROXIMATE GUIDE ONLY.
PRICES SHOWN ARE SUBJECT TO CHANGE WITHOUT PRIOR NOTICE.

F-25

BỘ DỤNG CỤ TOOL ASS'Y

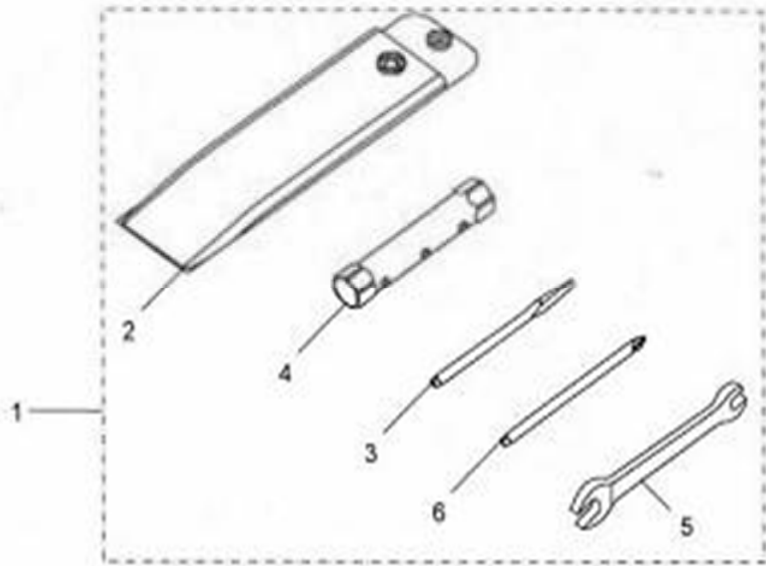

STT No.	VMEP CODE	(RM) Selling Price	Description	Unit	Ghi chú Remark
1	89010-M51-0000-OA	11.20	Tool Ass'y	1	

PRICE SHOWN IS PER PIECE. PRODUCT IMAGE PRICES ARE APPROXIMATE GUIDE ONLY.
PRICES SHOWN ARE SUBJECT TO CHANGE WITHOUT PRIOR NOTICE.

BAÛNG TRA MAÛ SỐÁ
PART NO. INDEX

Maõ sốá phui tuøng	Soá thòu tí	Maõ sốá phui tuøng	Soá thòu tí	Maõ sốá phui tuøng	Soá thòu tí	Maõ sốá phui tuøng	Soá thòu tí	Maõ sốá phui tuøng	Soá thòu tí
Part. No.	No.	Part. No.	No.	Part. No.	No.	Part. No.	No.	Part. No.	No.
10000		12342-X01-0000	E14	13381-VA2-3001	E15	15311-VA2-0002	E09	17221-VA2-0000	F12
10099-986-1500	F02	12342-X01-0000	F12	14100-VA2-0003	E03	15321-VA2-0002	E09	17230-VA2-0005(X)	F12
11100-SAB-0002	E14	12361-M9Q-0000	E01	14311-VA2-3000	E15	15331-VA2-0001	E09	17231-VA2-0001(X)	F12
11191-VN7-0000	E14	12391-VN7-0000	E01	14321-VA2-0001	E04	15332-VA2-0001	E09	17253-VA2-0000	F12
11200-SAB-0000	E14	12394-VN7-0000	E01	14431-M8Q-0000	E03	15341-VA2-0001	E15	17255-VA2-0000	F12
11321-A01-A000	E12	12395-VN7-0000	E01	14451-M8Q-0000	E03	15382-VA2-0001	E09	17500-SA5-0001	F11
11330-VA2-0000	E06	12396-SAE-0000	F10	14500-A01-A000	E04	15421-M8Q-0000	E09	17620-VA3-0000	F11
11338-M3G-0003	E06	13000-VA1-0002	E15	14502-M8Q-0000	E04	15436-M3G-0100	E07	17910-SAH-0000	F02
11341-VA2-0000	E10	13010-VA2-0000	E15	14531-A08-0000	E04	15439-VA2-0000	E07	17950-VAH-A000	F02
11360-VA2-9000	E10	13012-VA2-3050	E15	14541-M8Q-0100	E04	1565A-VA1-0000	E06	1795A-VAH-0000	F02
11394-VN7-0000	E06	13013-VA2-3050	E15	14550-M8Q-0000	E04	1576A-VA2-0006(X)	E14	18000-SAE-0001	F13
11395-VN7-0000	E10	13014-VA2-3050	E15	14566-A08-0101	E04	16100-A04-A003-VN	E19	18240-SA5-0000	F13
12101-A04-A000	E05	13015-VA2-3050	E15	14610-VA2-0001	E04	16101-VA6-0000	E19	18291-X01-0000	F13
12191-VN7-0000	E05	13101-VA2-0000	E15	14615-VA2-0000	E04	16201-VN7-0000	E02	18300-SAE-0001	F13
12200-SA5-0001-VN	E02	13102-VA2-3050	E15	14670-VA2-0001	E04	16211-A01-A000	E02	18325-SA5-0002	F16
12209-H6B-0000	E03	13103-VA2-3050	E15	14675-VA2-0000	E04	16802-SA5-0002	F11	18425-SA5-0002	F16
1220A-A04-A002	E02	13104-VA2-3050	E15	14711-VA2-0001	E03	16820-SA5-0001	F11	1BL 12N5-3B	F21
12225-VA2-3002	E02	13105-VA2-3050	E15	14721-VA2-0001	E03	16920-SB1-0000	F11	1CS 25H X 62L	E12
12226-VA2-3002	E02	13111-A04-A000	E15	14751-M8Q-0000	E03	17110-SM1-0000-VN	E02	1CS 25H X 90L	E04
12237-GB4-6812	E02	13121-VA2-000	E15	14761-M8Q-0000	E03	17200-VA2-0001	F12	1CS 428H X 102L	F09
12245-GB4-6812	E02	13131-A31-000	E15	14771-A01-A000	E03	17211-VA2-0000	F12	1TV 2.5/2.75-17 TR4	F09
12251-VA2-0001	E02	13141-VA2-000	E15	14775-M9Q-0000	E03	17213-VA2-0000(X)	F12	1TV 2.5-17 V9331 6P	F09
12301-A01-A000	E01	13201-VA1-0001	E15	14781-A01-A000	E03	17214-VA2-0000(X)	F12		
12331-A01-A000	E01	13310-VA1-3002(X)	E15	15100-VA2-0004	E09	17215-VA2-0000(X)	F12		
12341-A04-A000	E01	13321-VA1-3003(X)	E15	15133-VA2-0001	E09	17216-VA2-0000(X)	F12		
								20000	
								22000-A05-0000	E08

PRICE SHOWN IS PER PIECE. PRODUCT IMAGE PRICES ARE APPROXIMATE GUIDE ONLY.
PRICES SHOWN ARE SUBJECT TO CHANGE WITHOUT PRIOR NOTICE.

BAÛNG TRA MAÛ SỐ
PART NO. INDEX

Maõ số phôi tương Part. No.	Số thòu tí No.	Maõ số phôi tương Part. No.	Số thòu tí No.	Maõ số phôi tương Part. No.	Số thòu tí No.	Maõ số phôi tương Part. No.	Số thòu tí No.	Maõ số phôi tương Part. No.	Số thòu tí No.
22100-A05-0000	E08	23117-M3G-0100	E07	24331-VA2-0000	E14	28221-A13-0000	E18	33402-VD3-0000	F03
22101-A05-3001(X)	E07	23120-A05-0000(X)	E07	24411-VA2-0001	E17	28251-VA2-0000	E18	33406-VD3-0000	F03
2210B-A05-0001-VN	E07	23122-A05-0000(X)	E07	24421-VA2-0000	E17	28262-A01-A000	E18	3340A-VD3-0002	F03
22111-M3G-0100	E07	23124-VA2-0001	E07	24422-VA2-0000	E17	28271-121-6900	E18	33411-VD3-0001	F03
22112-M3G-0100	E07	23126-A05-3000(X)	E07	24430-VA2-0002	E17	28281-035-0180	E18	33461-VD3-0001	F03
22121-A05-0000	E08	23211-VA2-0000	E16	24435-VA2-0001	E17	28300-SB7-0000(X)	F14	33462-VD3-0000	F03
22201-107-0000-A	E08	23217-M3G-0002	E08	24610-VA2-3002	E17	2830A-SB7-0000	F14	33602-SA5-0001	F19
22300-A05-0000-VN	E07	23221-VA2-0001	E16	24630-VA2-0003	E17	28311-SB7-0000(X)	F14	33652-SA5-0001	F19
22311-107-0002	E08	23421-VA2-0001	E16	24633-M8Q-3000(X)	E17			33701-SA5-0001	F19
22350-M3G-0101	E07	23422-VA2-0000	E16	24634-VA2-0001(X)	E17	30000		33702-SA5-0000	F19
22351-A05-0000	E08	23431-VA2-0000	E16	24635-VA2-3000(X)	E17	30400-SA5-0000	F21	33705-SA5-0000	F19
22361-A05-0002	E08	23441-VA2-0001	E16	24636-M8Q-3000(X)	E17	30410-SA5-000	F21	33741-E51-0001	F19
22401-M3G-0001	E08	23451-VA2-0000	E16	24641-M8Q-0000(X)	E17	30500-SA5-0000	F21	34600-SA1-0000	F21
22530-M3G-0101	E07	23461-VA2-0000	E16	24651-M8Q-0000	E17	3111A-VA2-0003	E11	34901-SA5-0000	F01
22606-M3G-0000	E07	23471-VA2-0000	E16	24652-A08-0001	E17	31120-VA2-0003	E11	34905-M9Q-0000	F03
22630-M3G-0001	E07	23481-VA2-0001	E16	24701-SA5-9000	F14	31141-VA2-0000	E11	34905-M9Q-0000	F19
22641-M3G-0100	E07	23802-M36-0000	E16	28102-M8Q-0000	E12	31200-SB1-0000	E13	34906-M9P-0000	F19
22711-SB1-0000	E16	23911-VA2-0000	E16	28103-M8Q-0000	E12	31502-VA3-0000	F21	34908-M9Q-0000	F19
22810-VA2-0000	E06	24211-VA2-0001	E17	28110-A01-A001	E12	31600-VN7-0000	F21	35010-SA5-0000	F03
22820-A01-A000	E06	24261-VA2-0000	E17	28117-A05-0000-VN	E12	32100-SA5-0002	F21	35100-SA5-0000	F03
22820-M3G-0001	E06	24263-M8Q-0000	E17	28120-A01-0000	E12	32161-T15-000	F21	35150-SAF-0000	F03
22821-M3G-0001	E06	24301-VA2-0002	E17	28125-M7Q-0001	E12	32961-VA2-0000	E10	35160-SAF-0000	F03
22822-M3G-0000	E06	24305-VA2-0001	E16	28126-253-0305	E12	33100-SAF-0001	F01	35170-SAF-0000	F03
22823-M3G-0000(X)	E06	24306-VA2-0000	E16	28128-A01-0000	E12	33102-SAF-0000	F01	35180-SAF-0000	F03
22864-VA2-0000	E06	24320-VA2-0000	E17	28211-178-0000	E18	33106-SAF-0000	F01	35200-M9Q-0001	F03

PRICE SHOWN IS PER PIECE. PRODUCT IMAGE PRICES ARE APPROXIMATE GUIDE ONLY.
PRICES SHOWN ARE SUBJECT TO CHANGE WITHOUT PRIOR NOTICE.

BAÛNG TRA MAÛ SỐÁ
PART NO. INDEX

Maõ sốá phui tuøng	Soá thòu tí	Maõ sốá phui tuøng	Soá thòu tí	Maõ sốá phui tuøng	Soá thòu tí	Maõ sốá phui tuøng	Soá thòu tí	Maõ sốá phui tuøng	Soá thòu tí
Part. No.	No.	Part. No.	No.	Part. No.	No.	Part. No.	No.	Part. No.	No.
35350-SA5-0001	F15	4260A-SAE-0002(X)	F09	44809-VA1-0000-M1(X)	F07	50326-SA5-0001-RE	F18	51400-VAG-0000	F05
35357-SA5-0001	F15	4260B-SAH-000	F09	44820-VA1-0000-M1(X)	F07	50326-SA5-0001-WF	F18	51500-VAG-0000	F05
3575A-VA2-0002	E10	42610-VA3-0000	F09	44830-SA5-0000	F01	50326-SA5-0001-YL	F18	51711-SB1-0000	F05
37200-SAH-0000	F01	42620-X01-0000	F09	44907-VA1-0000-M1(X)	F07	50500-SA6-0000	F15	51712-SB1-0000	F05
37211-SAF-0000	F01	42653-001-0041	F09	45100-VA1-0004-VN	F02	50520-SA1-0001	F15	51713-SB1-0000	F05
37800-SA1-0000	F11	42701-VD7-0000	F09	45121-VA1-0000	F07	50521-SA1-0000	F15	52100-SAE-0001-IC	F16
38110-SA5-0003	F21	42710-VA2-0002(X)	F09	45126-SAB-0000	F02	50524-SA1-0000	F15	52181-A08-3000	F16
38201-SA1-0000(X)	F21	43000-VDA-0000(X)	F08	4512B-ADA-0000	F08	50530-VA2-0001	F14	52400-SAE-0002	F17
38206-SA1-0000(X)	F21	43100-X01-0202-SE	F08	45133-A10-0000	F08	50610-SAE-0001	F14	53100-SAH-0001	F03
		43141-A02-0103	F08	45134-M9Q-0000	F08	5061A-VB4-0002(X)	F14	53102-VAE-0000	F02
	40000	43145-X01-0100	F08	45156-VA1-0002	F05	50661-VB4-0000	F14	53103-VAE-0000	F02
4051A-SA5-0000	F16	43410-M3B-0001	F08	45157-VA1-0001	F05	50713-SA1-0000	F16	53104-M3B-0000	F02
40543-VAD-000	F08	43450-SAH-0000	F15	45451-N02-0000	F04	50714-SA5-0000	F16	53104-M3B-0000	F02
40543-VAD-000	F09	43550-SB1-0000	F15	4550A-SAB-0000	F02	50830-SAE-0001	F16	53105-VAE-0000	F02
4054A-VAD-0000	F08	44301-VA5-0001	F07	46500-SA5-0001	F15	50840-SAE-0001	F16	53106-M9P-0000	F02
4054A-VAD-0000	F09	44311-M67-0000	F07	46513-SA1-0000	F15	51103-VA1-0002-BH1	F04	53108-N02-0001	F02
40591-SA5-0001	F16	44600-SAH-000	F07	47104-SB1-0000	F03	51103-VA1-0002-KB	F04	53108-N02-0001	F02
41201-RS1-0000	F09	44620-VA1-0000	F07			51103-VA1-0002-RE	F04	53140-VAH-0000	F02
41241-VDA-0001	F09	44680-VA1-000	F07		50000	51103-VA1-0002-WF	F04	53166-VAH-0000	F02
42242-SA1-0000	F15	44701-VD7-0000	F07	50100-SAE-0000	F22	51103-VA1-0002-YL	F04	53167-H09-0001	F02
42246-SA1-0000	F15	44710-VA2-000	F07	50306-VS1-0000	F05	51104-VA1-0002-BH1	F04	53168-H09-0001	F02
42301-SAE-0000	F09	44800-VA1-0001	F07	50320-SA5-0000	F22	51104-VA1-0002-KB	F04	53175-VN3-000	F02
42304-SAE-0000	F09	44803-VA1-0000-M1(X)	F07	50322-SA5-0000	F22	51104-VA1-0002-RE	F04	53200-VX3-0000	F05
42305-SAE-0002	F09	44805-VA1-0000-M1(X)	F07	50326-SA5-0001-BH1	F18	51104-VA1-0002-WF	F04	53205-SAF-0003-BH1	F03
42313-SAH-0000	F08	44806-VA1-0001-M1(X)	F07	50326-SA5-0001-KB	F18	51104-VA1-0002-YL	F04	53205-SAF-0003-KB	F03

PRICE SHOWN IS PER PIECE. PRODUCT IMAGE PRICES ARE APPROXIMATE GUIDE ONLY.
PRICES SHOWN ARE SUBJECT TO CHANGE WITHOUT PRIOR NOTICE.

BAŨNG TRẢ MÃ SỐ
PART NO. INDEX

Maõ số phôi tương Part. No.	Số thòu tí No.	Maõ số phôi tương Part. No.	Số thòu tí No.	Maõ số phôi tương Part. No.	Số thòu tí No.	Maõ số phôi tương Part. No.	Số thòu tí No.	Maõ số phôi tương Part. No.	Số thòu tối No.
53205-SAF-0003-RE	F03	64302-SA5-0003-BH1	F06	77210-SAH-0003(X)	F10	83600-SA5-0004-BH1	F18	87127-SAH-0000-T1	F24
53205-SAF-0003-WF	F03	64302-SA5-0003-KB	F06	77211-SAE-0000	F10	83600-SA5-0004-KB	F18	87127-SAH-0000-T2	F24
53205-SAF-0003-YL	F03	64302-SA5-0003-RE	F06	77212-SAE-0000	F10	83600-SA5-0004-RE	F18	87127-SAH-0000-T5	F24
53206-SAF-0001	F03	64302-SA5-0003-WH	F06	77226-M3F-0000	F04	83600-SA5-0004-WH	F18	87127-SAH-0001-T3	F24
5320A-SAE-0000(X)	F05	64302-SA5-0003-YL	F06	77226-M3F-0000	F18	83600-SA5-0004-YL	F18	87127-SAH-0001-T4	F24
53212-VA3-0000	F05	64303-SA5-0002-RB	F06	77230-SA5-0000	F22	83650-SA5-0000-IF	F18	87133-SAH-0000-T1	F24
53214-X04-0000	F05	64303-SA5-0002-SV	F06	77232-F3C-0002	F18	87000-SAH-0000-T1	F24	87133-SAH-0001-T2	F24
53215-X04-0001	F05	64304-SA5-0002-RB	F06	77239-SA5-0000	F18	87121-SAH-0000-T5	F24	87133-SAH-0002-T3	F24
53220-VA3-0001	F05	64304-SA5-0002-SV	F06	77240-SA5-0001	F22	87121-SAH-0001-T1	F24	87133-SAH-0002-T4	F24
54207-SB1-0000	F07	64304-X01-0000	F06			87121-SAH-0001-T2	F24	87133-SAH-0002-T5	F24
		64304-X01-0000	F18	80000		87121-SAH-0001-T3	F24	87134-SAH-0000-T1	F24
60000		64304-X01-0000	F19	80100-SA5-0000	F19	87121-SAH-0001-T4	F24	87134-SAH-0000-T5	F24
61200-VA1-0003-BH1	F04	64305-SA5-A000	F06	80152-SA5-0000	F18	87122-SAH-0000-T4	F24	87134-SAH-0001-T2	F24
61200-VA1-0003-KB	F04	64306-X01-0000	F18	80200-SA5-0001	F19	87122-SAH-0000-T5	F24	87134-SAH-0001-T3	F24
61200-VA1-0003-RE	F04	64306-X01-0000	F19	81200-SA5-9000	F20	87122-SAH-0001-T1	F24	87134-SAH-0001-T4	F24
61200-VA1-0003-WF	F04	64307-SA5-A000	F06	81204-H6T-0000	F20	87122-SAH-0001-T2	F24	87135-SAH-0000-T1	F24
61200-VA1-0003-YL	F04	64310-SA5-0005-RB	F04	83400-SA5-0000	F19	87122-SAH-0001-T3	F24	87135-SAH-0000-T5	F24
61201-M3G-0000-A	F04	64310-SA5-0005-SV	F04	83500-SA5-0004-BH1	F18	87123-H85-0000	F04	87135-SAH-0001-T2	F24
61251-SA1-0000	F16	64312-SA5-0000-IF	F04	83500-SA5-0004-KB	F18	87123-SA5-0002-BH1	F18	87135-SAH-0001-T3	F24
64100-SA5-0000	F06	65311-SA1-0000	F16	83500-SA5-0004-RE	F18	87123-SA5-0002-KB	F18	87135-SAH-0001-T4	F24
64301-SA5-0003-BH1	F06			83500-SA5-0004-WH	F18	87123-SA5-0002-RE	F18	87136-SAH-0000-T1	F24
64301-SA5-0003-KB	F06	70000		83500-SA5-0004-YL	F18	87123-SA5-0002-WH	F18	87136-SAH-0000-T5	F24
64301-SA5-0003-RE	F06	75581-M9Q-0001	F18	83503-SA6-0000-T1	F24	87123-SA5-0002-YL	F18	87136-SAH-0001-T2	F24
64301-SA5-0003-WH	F06	77200-SAH-0003	F10	83550-SA5-0000-IF	F18	87125-SAH-0000-T5	F24	87136-SAH-0001-T3	F24
64301-SA5-0003-YL	F06	77206-M51-0000	F10	83551-SB1-0000	F22	87126-SAH-0000-T5	F24	87136-SAH-0001-T4	F24

PRICE SHOWN IS PER PIECE. PRODUCT IMAGE PRICES ARE APPROXIMATE GUIDE ONLY.
PRICES SHOWN ARE SUBJECT TO CHANGE WITHOUT PRIOR NOTICE.

BAÛNG TRA MAÛ SỐÁ
PART NO. INDEX

Maõ sốá phui tuøng	Soá thòu tí	Maõ sốá phui tuøng	Soá thòu tí	Maõ sốá phui tuøng	Soá thòu tí	Maõ sốá phui tuøng	Soá thòu tí	Maõ sốá phui tuøng	Soá thòu tí
Part. No.	No.	Part. No.	No.	Part. No.	No.	Part. No.	No.	Part. No.	No.
87505-X01-0001-L1	F23	90104-VA1-0000	F18	90302-SA4-003B	F06	90462-VA2-0000	E16	91201-VA2-0000	E12
87508-VR3-0000	F23	90105-M40-0000	F03	90302-SA4-003B	F18	90463-VA2-0000	E16	91202-A01-0000	E12
87510-KAG-0000	F23	90105-VA1-0001	F05	90306-SB1-0000	F09	90464-VA2-0000	E08	91202-VA2-0000	E06
87512-VA2-0000	F23	90106-TAA-0001	F03	90308-M36-0000	F13	90479-X01-0000	E17	91203-VA2-0000	E16
88110-SA5-9000	F02	90108-B06-0001	F14	90309-M9Q-0000	F22	90481-035-0001	E04	91208-VA2-0000	E17
88120-SA5-9000	F02	90110-GZ0-000A	F06	90344-SA1-0000	F22	90485-A08-0001	E06	91252-030-003A	F07
89010-M51-0000-OA	F25	90110-GZ0-000A	F18	90401-M3G-0000	E07	90601-A08-0001	E16	91258-410-0131	F07
		90111-M9Q-9000	F16	90405-VA2-0000	E04	90603-A05-0000(X)	E07	91301-VA2-0000	E14
	90000	90111-VA2-0000	F19	90407-SB1-0000	E14	90605-A08-0002	E16	91302-M9Q-0000	E01
90002-VA2-0000	E09	90111-VA2-0000	F22	90431-M3G-0001	E07	90605-A08-0002	E18	91302-VA2-0000	E12
90012-M9Q-0000	E03	90112-M67-0000	F16	90432-SB1-0000	E07	90651-T36-0000	F01	91303-M2Q-0000	E10
90031-VA1-0002	E14	90115-VA3-0000	F03	90432-SB1-0000	E08	90702-M9Q-000	E03	91305-028-1583	E02
90032-VA1-0002	E14	90115-VA3-0000	F18	90434-M3G-0000	E07	90702-M9Q-000	E05	91307-B06-0000	E06
90071-M8Q-0000	E17	90116-SA1-0000	F16	90441-M8Q-0000	E04	90702-M9Q-000	E06	91308-M9Q-0000	E02
90081-035-0006	E04	90117-SA1-0000	F16	90442-VA2-0000	E01	90702-M9Q-000	E09	91308-VA2-0000(X)	E10
90081-VA2-0000	E02	90122-VA1-0000	F02	90443-VA2-0000	E01	90702-M9Q-000	E10	91312-A01-A001	E06
90081-VA2-0000	E05	90127-M8Q-0000	F08	90444-VA2-0000	E09	90703-HC4-0000	E14	91318-VA2-0000	E12
90083-A08-0000	E04	90164-X01-0002	F03	90452-VA2-0000	E16	90741-M8Q-0000	E15	92101-06010-OH	E16
90084-A01-A000(X)	E10	90186-VA6-0001	F20	90452-VA2-0000	E18	90753-029-003A	F09	92101-06020-0A	F14
90087-A01-A000(X)	E10	90201-VA2-0002	E01	90454-B04-0002	E18	90912-M9Q-0000-M1	E16	92101-06028-0H	F14
9008A-M8Q-0000	E10	90206-001-0007	E03	90455-M3G-0000	E07	91001-M36-0001	E15	92101-08020-0A	F14
9008B-M8Q-0000	E10	90231-M8Q-0000	E07	90461-VA2-0001	E01	91002-VA2-0000	E15	92101-08032-0A	F09
90101-VD3-0001	F01	90231-VA2-0000	E08	90461-VA2-0001	E04	91021-148-0040	E06	92700-A02-0001	E02
90104-VA1-0000	F03	90302-SA4-003B	F03	90461-VA2-0001-M1	E16	91101-M3G-0000	E07	92800-12000	E14
90104-VA1-0000	F04	90302-SA4-003B	F04	90462-VA2-0000	E16	91101-M8Q-0000	E12	93404-06012-00	F18

PRICE SHOWN IS PER PIECE. PRODUCT IMAGE PRICES ARE APPROXIMATE GUIDE ONLY.
PRICES SHOWN ARE SUBJECT TO CHANGE WITHOUT PRIOR NOTICE.

BAÏNG TRA MAÏ SOÁ
PART NO. INDEX

Maï soá phui tuøng	Soá thòu tí	Maï soá phui tuøng	Soá thòu tí	Maï soá phui tuøng	Soá thòu tí	Maï soá phui tuøng	Soá thòu tí	Maï soá phui tuøng	Soá thòu tí
Part. No.	No.	Part. No.	No.	Part. No.	No.	Part. No.	No.	Part. No.	No.
93404-06016-00	F19	93903-35220-00	F06	94101-10000-00	F17	95701-06022-08	E08	96001-06028-07	E10
93500-05006-0A	E11	93903-44320-00	F04	94101-12000-00	F17	95701-06032-00	F08	96001-06032-08	E10
93500-05008-0A	E07	93903-44480	F03	94103-08000	F20	95701-06035-00	E09	96001-06040-00	E06
93500-05008-0A	F13	93903-44480	F04	94108-11000-00	F09	95701-06040-00	E09	96001-06050-00	E10
93500-05010-0A	E11	93903-44480	F06	94111-05000	F13	95701-06110-00	E01	96001-06050-00	E13
93500-05016-0H	F21	93903-44480	F18	94111-06000-00	F08	95801-06012-00	F11	96001-06050-00	E14
93500-05022-00	F02	94001-06000-00	F08	94111-06000-00	F09	95801-06012-00	F12	96001-06060-08	E14
93600-06010-0A	E06	94001-06000-00	F09	94111-08000	F14	95801-06012-00	F21	96001-06065-00	E06
93600-06016-0A	E12	94001-10000-0S	F17	94111-10000-00	F08	95801-06012-00	F22	96001-06065-00	E14
93700-06060-0G	F02	94002-10080-0S	F14	94201-20151	F15	95801-06014-00	F04	96001-06070-08	E10
93700-06065-0G	F02	94021-10000	F17	94201-30280	F15	95801-06016-08	F18	96001-06080-00	E06
93891-05022-07	F07	94030-08000-00	E06	94251-08400	F08	95801-06020-00	F04	96100-60000-00	E08
93891-06016-07	F22	94030-08000-00	F09	94303-03050	E15	95801-06020-00	F19	96100-62030-00	E16
93901-24310	F12	94050-05080-00	F19	94504-03018(X)	E06	95801-08016-08	F11	96100-62030-00	F09
93901-34320	F19	94050-06000-00	F08	94510-16000-00	E18	95801-08020-00	F20	96140-60010-00	E06
93903-24220-10	F03	94050-06080	F10	94540-05018	E09	95801-VD7-0000	F07	96140-60010-00	E16
93903-24220-10	F18	94050-06080	F11	94540-07010	E07	96001-06010-08	E12	96140-63010-10	F07
93903-24380	F18	94050-08000	F08	94601-13000-00	E15	96001-06010-08	F05	96140-63010-10	F09
93903-25410	F12	94050-10080-00	F03	95002-70000(X)	E14	96001-06012-08	E10	9621A-06000-00	F05
93903-34320-00	F04	94050-12000	E11	95014-72102-OB	F14	96001-06016-00	E10	96220-30085	E17
93903-34320-00	F06	94101-05000	F13	95015-32001-00	F15	96001-06022-02	E11	96220-30158	E09
93903-34320-00	F18	94101-05000	F15	95015-42000-00	F15	96001-06025-00	E01	96700-06012-08-L1	F02
93903-34480-00	F03	94101-06000	F08	95301-08100-00	F22	96001-06025-00	E02	96700-06016-00	E17
93903-35180-00	F03	94101-06000	F09	95301-08110-00	F22	96001-06025-00	E14		
93903-35220-00	F01	94101-08000	F08	95701-06018-07	E04	96001-06028-07	E02		

PRICE SHOWN IS PER PIECE. PRODUCT IMAGE PRICES ARE APPROXIMATE GUIDE ONLY.
PRICES SHOWN ARE SUBJECT TO CHANGE WITHOUT PRIOR NOTICE.

BAÛNG TRA MAÛ SỐ
PART NO. INDEX

Maõ số phui tuøng	Đoá thòu tí	Maõ số phui tuøng	Đoá thòu tí	Maõ số phui tuøng	Đoá thòu tí	Maõ số phui tuøng	Đoá thòu tí	Maõ số phui tuøng	Đoá thòu tí
Part. No.	No.	Part. No.	No.	Part. No.	No.	Part. No.	No.	Part. No.	No.

PLUG

AC-1201-0001	E01								
--------------	-----	--	--	--	--	--	--	--	--